

BS EN 545:2010



BSI Standards Publication

Ductile iron pipes, fittings, accessories and their joints for water pipelines — Requirements and test methods

NO COPYING WITHOUT BSI PERMISSION EXCEPT AS PERMITTED BY COPYRIGHT LAW

raising standards worldwide™



National foreword

This British Standard is the UK implementation of EN 545:2010. It supersedes BS EN 545:2006 which is withdrawn.

The UK participation in its preparation was entrusted to Technical Committee PSE/10, Iron pipes and fittings.

A list of organizations represented on this committee can be obtained on request to its secretary.

This publication does not purport to include all the necessary provisions of a contract. Users are responsible for its correct application.

© BSI 2010

ISBN 978 0 580 69790 6

ICS 23.040.10; 23.040.40

Compliance with a British Standard cannot confer immunity from legal obligations.

This British Standard was published under the authority of the Standards Policy and Strategy Committee on 31 October 2010.

Amendments issued since publication

Date	Text affected
------	---------------

EUROPEAN STANDARD

EN 545

NORME EUROPÉENNE

EUROPÄISCHE NORM

September 2010

ICS 23.040.10; 23.040.40

Supersedes EN 545:2006

English Version

Ductile iron pipes, fittings, accessories and their joints for water pipelines - Requirements and test methods

Tuyaux, raccords et accessoires en fonte ductile et leurs assemblages pour canalisations d'eau - Prescriptions et méthodes d'essai

Rohre, Formstücke, Zubehörteile aus duktilem Gusseisen und ihre Verbindungen für Wasserleitungen - Anforderungen und Prüfverfahren

This European Standard was approved by CEN on 12 August 2010.

CEN members are bound to comply with the CEN/CENELEC Internal Regulations which stipulate the conditions for giving this European Standard the status of a national standard without any alteration. Up-to-date lists and bibliographical references concerning such national standards may be obtained on application to the CEN Management Centre or to any CEN member.

This European Standard exists in three official versions (English, French, German). A version in any other language made by translation under the responsibility of a CEN member into its own language and notified to the CEN Management Centre has the same status as the official versions.

CEN members are the national standards bodies of Austria, Belgium, Bulgaria, Croatia, Cyprus, Czech Republic, Denmark, Estonia, Finland, France, Germany, Greece, Hungary, Iceland, Ireland, Italy, Latvia, Lithuania, Luxembourg, Malta, Netherlands, Norway, Poland, Portugal, Romania, Slovakia, Slovenia, Spain, Sweden, Switzerland and United Kingdom.



EUROPEAN COMMITTEE FOR STANDARDIZATION
COMITÉ EUROPÉEN DE NORMALISATION
EUROPÄISCHES KOMITEE FÜR NORMUNG

Management Centre: Avenue Marnix 17, B-1000 Brussels

Contents

Page

Foreword.....	6
1 Scope	7
2 Normative references	7
3 Terms and definitions	8
4 Technical requirements	12
4.1 General.....	12
4.2 Pressure class.....	13
4.3 Dimensional requirements.....	14
4.4 Material characteristics.....	18
4.5 Coatings and linings for pipes	19
4.6 Coatings for fittings and accessories.....	21
4.7 Marking of pipes, fittings and accessories	22
4.8 Leak tightness.....	23
5 Performance requirements for joints and pipe saddles	23
5.1 General.....	23
5.2 Flexible joints	23
5.3 Restrained flexible joints	25
5.4 Flanged joints as cast, screwed, welded and adjustable	25
5.5 Pipe saddles	26
6 Test methods.....	27
6.1 Pipe dimensions	27
6.2 Straightness of pipes	28
6.3 Tensile testing.....	28
6.4 Brinell hardness.....	30
6.5 Works leak tightness test for pipes and fittings.....	30
6.6 Zinc mass	30
6.7 Thickness of paint coatings	31
6.8 Thickness of cement mortar lining	31
7 Performance test methods	32
7.1 Compressive strength of the cement mortar lining	32
7.2 Leak tightness of flexible joints	32
7.3 Leak tightness and mechanical resistance of flanged joints.....	35
7.4 Leak tightness and mechanical resistance of pipe saddles	36
8 Tables of dimensions	37
8.1 Socket and spigot pipes	37
8.2 Flanged pipes.....	40
8.3 Fittings for socketed joints.....	40
8.4 Fittings for flanged joints.....	56
9 Evaluation of conformity.....	73
9.1 General.....	73
9.2 Initial performance testing.....	73
9.3 Factory production control (FPC)	75
Annex A (normative) Allowable pressures	80
A.1 General.....	80
A.2 Socket and spigot pipes (see 8.1)	80
A.3 Fittings for socketed joints (see 8.3)	80
A.4 Flanged pipes (see 8.2) and fittings for flanged joints (see 8.4).....	81
A.5 Accessories.....	81

Annex B (informative) Longitudinal bending resistance of pipes	82
Annex C (informative) Diametral stiffness of pipes	83
Annex D (informative) Specific coatings, field of use, characteristics of soils	86
D.1 Alternative coatings	86
D.2 Field of use in relation to the characteristics of soils	87
Annex E (informative) Field of use, water characteristics	89
Annex F (informative) Calculation method of buried pipelines, heights of cover	90
F.1 Calculation method	90
F.2 Heights of cover	92
Bibliography	93

Tables

Table 1 — Limit deviations on thickness of fittings	14
Table 2 — Limit deviation on internal diameter	15
Table 3 — Maximum DN for limit deviations on internal diameter for pressure classes	15
Table 4 — Standardized lengths of socket and spigot pipes	15
Table 5 — Standardized lengths of flange pipes	16
Table 6 — Permissible deviation on lengths of fittings	16
Table 7 — Limit deviations on length	18
Table 8 — Tensile properties	18
Table 9 — Thickness of cement mortar lining	21
Table 10 — DN groupings for performance tests	23
Table 11 — Performance tests for joints	24
Table 12 — Bending moments for flange joint performance tests	26
Table 13 — Performance tests for pipe saddles	27
Table 14 — Dimensions of test bar	29
Table 15 — Works test pressure for pipes not centrifugally cast, fittings and accessories	30
Table 16 — Dimensions of pipes of preferred pressure classes	38
Table 17 — Dimensions of pipes	39
Table 18 — Dimensions of flanged sockets	41
Table 19 — Dimensions of flanged spigots and collars	43
Table 20 — Dimensions of double socket 90° and 45° bends	45
Table 21 — Dimensions of double socket 22,5° and 11,25° bends	47
Table 22 — Dimensions of all socket tees	49
Table 23 — Dimensions of double socket tees with flanged branch, DN 40 to 250	51
Table 24 — Dimensions of double socket tees with flanged branch, DN 300 to DN 700	52
Table 25 — Dimensions of double socket tees with flanged branch, DN 800 to DN 2 000	53
Table 26 — Dimensions of double socket tapers	55
Table 27 — Dimensions of double flanged 90° and 90° duckfoot bends	57

Table 28 — Dimensions of double flanged 45° bends	59
Table 29 — Dimensions of double flanged 22,5° and 11,25° bends	61
Table 30 — Dimensions of all flanged tees, DN 40 to DN 250	62
Table 31 — Dimensions of all flanged tees, DN 300 to DN 700	63
Table 32 — Dimensions of all flanged tees, DN 800 to DN 2000	64
Table 33 — Dimensions of double flanged tapers	66
Table 34 — Dimensions of PN 10 and PN 16 blank flanges	68
Table 35 — Dimensions of PN 25 and PN 40 blank flanges	70
Table 36 — Dimensions of PN 10 and PN 16 reducing flanges	71
Table 37 — Dimensions of PN 25 and PN 40 reducing flanges	73
Table 38 — Number of test samples for initial performance testing	75
Table 39 — Minimum frequency of product testing as part of FPC	77
Table 40 — Maximum batch sizes for tensile testing.....	78
Table A.1 — Fittings pressure class	81
Table A.2 — Flanged pipe and fittings pressures	81
Table B.1 — Longitudinal bending moment resistance of pipes.....	82
Table C.1 — Diametral stiffness of pipes of preferred pressure classes	85
Table E.1 — Field of use for cement mortar linings.....	89
Table F.1 — Heights of cover for pipes of preferred pressure classes	92

Figures

Figure 1 — Leak tightness test of joints (internal pressure).....	33
Figure 2 — Leak tightness test of joints (external pressure).....	34
Figure 3 — Strength and leak tightness test for flanged joints	35
Figure 4 — Leak tightness test for pipe saddles.....	36
Figure 5 — Socket and spigot pipes.....	37
Figure 6 — Flanged sockets	40
Figure 7 — Flanged spigots.....	42
Figure 8 — Collars	42
Figure 9 — Double socket 90° (1/4) bends	44
Figure 10 — Double socket 45° (1/8) bends	44
Figure 11 — Double socket 22°30' (1/16) bends	46
Figure 12 — Double socket 11°15' (1/32) bends	46
Figure 13 — All socket tees	48
Figure 14 — Double socket tees with flanged branch	50
Figure 15 — Double socket tapers.....	54
Figure 16 — Double flanged 90° (1/4) bends.....	56
Figure 17 — Double flanged duckfoot 90° (1/4) bends	57

Figure 18 — Double flanged 45° (1/8) bends	58
Figure 19 — Double flanged 22°30' (1/16) bends	60
Figure 20 — Double flanged 11°15' (1/32) bends	60
Figure 21 — All flanged tees	61
Figure 22 — Double flanged tapers	65
Figure 23 — Blank flanges PN 10	67
Figure 24 — Blank flanges PN 16	67
Figure 25 — Blank flanges PN 25	69
Figure 26 — Blank flanges PN 40	69
Figure 27 — Reducing flanges PN 10	70
Figure 28 — Reducing flanges PN 16	71
Figure 29 — Reducing flanges PN 25	72
Figure 30 — Reducing flanges PN 40	72

Foreword

This document (EN 545:2010) has been prepared by Technical Committee CEN/TC 203 “Cast iron pipes, fittings and their joints”, the secretariat of which is held by AFNOR.

This European Standard shall be given the status of a national standard, either by publication of an identical text or by endorsement, at the latest by March 2011, and conflicting national standards shall be withdrawn at the latest by March 2011.

Attention is drawn to the possibility that some of the elements of this document may be the subject of patent rights. CEN [and/or CENELEC] shall not be held responsible for identifying any or all such patent rights.

This document supersedes EN 545:2006.

In this standard Annex A is normative and Annexes B, C, D, E and F are informative.

This standard is in conformity with the general requirements already established by CEN/TC 164 in the field of water supply.

In respect of potential adverse effects on the quality of water intended for human consumption, caused by the products covered by this standard:

- this standard provides no information as to whether the products may be used without restriction in any of the member states of the EU or EFTA;
- it should be noted that, while awaiting the adoption of verifiable European criteria, existing national regulations concerning the use and/or the characteristics of these products remain in force.

According to the CEN/CENELEC Internal Regulations, the national standards organizations of the following countries are bound to implement this European Standard: Austria, Belgium, Bulgaria, Croatia, Cyprus, Czech Republic, Denmark, Estonia, Finland, France, Germany, Greece, Hungary, Iceland, Ireland, Italy, Latvia, Lithuania, Luxembourg, Malta, Netherlands, Norway, Poland, Portugal, Romania, Slovakia, Slovenia, Spain, Sweden, Switzerland and the United Kingdom.

1 Scope

This European Standard specifies the requirements and associated test methods applicable to ductile iron pipes, fittings, accessories and their joints for the construction of pipelines outside buildings:

- to convey different types of water (e.g. raw water, treated water, re-used water) for all types of applications (e.g. water intended for human consumption, for fire protection, for snow making, for irrigation, for hydro-electricity etc.);
- with or without pressure;
- to be installed below or above ground.

This European Standard is applicable to pipes, fittings and accessories which are:

- manufactured with socketed, flanged or spigot ends;
- supplied externally and internally coated;
- suitable for fluid temperatures between 0 °C and 50 °C, excluding frost;
- not intended for use in areas subject to reaction to fire regulations.

This does not preclude special arrangements for the products to be used at higher temperatures.

This European Standard covers pipes and fittings cast by any type of foundry process or manufactured by fabrication of cast components, as well as corresponding joints and accessories, in a size range extending from DN 40 to DN 2 000, inclusive.

This European Standard specifies requirements for materials, dimensions and tolerances, mechanical properties and standard coatings of ductile iron pipes and fittings. It also gives performance requirements for all components including joints. Joint design and gasket shapes are outside the scope of this standard.

In addition, reference is made to the minimum performance requirements of couplings, flange adaptors and saddles manufactured for use with ductile iron pipes and fittings.

NOTE In this European Standard, all pressures are relative pressures, expressed in bars (100 kPa = 1 bar).

2 Normative references

The following referenced documents are indispensable for the application of this document. For dated references, only the edition cited applies. For undated references, the latest edition of the referenced document (including any amendments) applies.

EN 196-1, *Methods of testing cement — Part 1: Determination of strength*

EN 197-1, *Cement – Part 1: Composition, specifications and conformity criteria for common cements*

EN 681-1, *Elastomeric seals — Material requirements for pipe joint seals used in water and drainage applications — Part 1: Vulcanized rubber*

EN 805:2000, *Water supply — Requirements for systems and components outside buildings*

EN 1092-2, *Flanges and their joints — Circular flanges for pipes, valves, fittings and accessories, PN designated — Part 2: Cast iron flanges*

EN 1333:2006, *Flanges and their joints — Pipework components — Definition and selection of PN*

EN 14901, *Ductile iron pipes, fittings and accessories — Epoxy coating (heavy duty) of ductile iron fittings and accessories — Requirements and test methods*

EN ISO 4016, *Hexagon head bolts — Product grade C (ISO 4016:1999)*

EN ISO 4034, *Hexagon nuts — Product grade C (ISO 4034:1999)*

EN ISO 6506-1, *Metallic materials — Brinell hardness test — Part 1: Test method (ISO 6506-1:2005)*

EN ISO 6892-1, *Metallic materials — Tensile testing — Part 1: Method of test at room temperature (ISO 6892-1:2009)*

EN ISO 7091, *Plain washers — Normal series — Product grade C (ISO 7091:2000)*

EN ISO 9001:2000, *Quality management systems — Requirements (ISO 9001:2000)*

3 Terms and definitions

For the purposes of this document, the following terms and definitions apply.

3.1 ductile iron

cast iron used for pipes, fittings and accessories in which graphite is present substantially in spheroidal form

3.2 pipe

casting of uniform bore, straight in axis, having socket, spigot or flanged ends, except for flanged socket pieces, flanged spigot pieces and collars which are classified as fittings

3.3 fitting

casting other than a pipe which allows pipeline deviation, change of direction or bore

NOTE In addition flanged socket pieces, flanged spigot pieces and collars are also classified as fittings.

3.4 accessory

any casting/fabrication other than a pipe or fitting which is intended for use in a ductile iron pipeline including:

- Glands and bolts for mechanical flexible joints (see 3.14);
- Glands, bolts and locking rings for restrained flexible joints (see 3.15);
- Pipe saddles for service pipe connections;
- Adjustable flanges and flanges to be welded or screwed;
- Flange adaptors for use with ductile iron pipes and fittings (see 4.1.3.2);
- Couplings for use with ductile iron pipes and fittings (see 4.1.3.2)

NOTE 1 Valves of all types are not covered by the term accessory.

NOTE 2 Wide tolerance flange adaptors and couplings are covered by EN 14525.

3.5

component

any product defined in 3.2 to 3.4

3.6

flange

end of a pipe, fitting or accessory extending perpendicular to its axis, with bolt holes equally spaced on a circle

NOTE A flange can be fixed (e.g. integrally cast, screwed or welded) or adjustable; an adjustable flange comprises a ring, in one or several parts assembled together, which bears on an end joint hub and can be freely rotated around the barrel axis before jointing.

3.7

spigot

male end of a pipe or fitting

3.8

spigot end

maximum insertion depth of the spigot plus 50 mm

3.9

socket

female end of a component to make the connection with the spigot of the next component

3.10

gasket

sealing component of a joint

3.11

joint

connection between the ends of two components in which a gasket is used to effect a seal

3.12

flexible joint

joint which permits significant angular deflection both during and after installation and which can accept a slight offset of the centreline

3.13

push-in flexible joint

flexible joint assembled by pushing the spigot through the gasket in the socket of the mating component

3.14

mechanical flexible joint

flexible joint in which sealing is obtained by applying pressure to the gasket by mechanical means, e.g. a gland

3.15

restrained flexible joint

flexible joint in which a means is provided to prevent separation of the assembled joint

3.16

flanged joint

joint between two flanged ends

3.17
nominal size
DN

alphanumerical designation of size for components of a pipework system, to be used for reference purposes, which comprises the letters DN followed by a dimensionless whole number which is indirectly related to the physical size, in millimetres, of the bore or outside diameter of the end connections

[EN ISO 6708:1995]

3.18
nominal pressure
PN

alphanumerical designation related to a combination of mechanical and dimensional characteristics of a component of a pipework system, to be used for reference purposes, which comprises the letters PN followed by a dimensionless number

[EN 1333:2006]

NOTE All components of the same nominal size DN and designated by the same PN number have compatible mating dimensions.

3.19
leak tightness test pressure

pressure applied to a component during manufacture in order to ensure its leak tightness

3.20
allowable operating pressure
PFA

maximum hydrostatic pressure that a component is capable of withstanding continuously in service

[EN 805:2000]

3.21
pressure class
C

alphanumerical designation of a family of components, including their joints, relating to their operating pressures as verified by all the performance tests described in this standard, which includes the letter C followed by a dimensionless number equal to the maximum PFA in bars of the family of components

3.22
allowable maximum operating pressure
PMA

maximum pressure occurring from time to time, including surge, that a component is capable of withstanding in service

[EN 805:2000]

3.23
allowable test pressure
PEA

maximum hydrostatic pressure that a newly installed component is capable of withstanding for a relatively short duration, in order to insure the integrity and tightness of the pipeline

[EN 805:2000]

NOTE This test pressure is different from the system test pressure (STP), which is related to the design pressure of the pipeline and is intended to ensure its integrity and leak tightness.

3.24

diametral stiffness of a pipe

characteristic of a pipe which allows it to resist ovalization under loading when installed

3.25

performance test

proof of design test which is done once and must be repeated after each change of design

3.26

laying length

length by which a pipeline progresses when an additional pipe or fitting is installed

NOTE For socketed pipes and fittings the laying length L_e is equal to the overall length (OL) minus the maximum spigot insertion depth (X) as given by the manufacturer. For flanged pipes and fittings, the laying length is equal to the overall length.

3.27

standardized length

length of pipe barrel and fitting body or branch, as specified in this standard (see 4.3.3)

NOTE For socketed pipes (see Figure 5) and socketed fittings, the standardized length, L_u (l_u for branches), is equal to the overall length (OL) minus the depth of the socket (DOS) as given by the manufacturer. For flanged pipes and fittings, the standardized length, L (l for branches), is equal to the overall length.

3.28

deviation

design length allowance with respect to the standardized length of a pipe or a fitting

3.29

ovality

out of roundness of a pipe section

NOTE It is equal to: $100 \left(\frac{A_1 - A_2}{A_1 + A_2} \right)$

where:

A_1 is the maximum axis, in millimetres;

A_2 is the minimum axis, in millimetres.

3.30

pipe minimum thickness

minimum thickness at any point of the pipe (see Tables 16 and 17) used in the calculation of its PFA and pressure class

3.31

thickness for pipe stiffness calculation

thickness based on the pipe minimum thickness and the DN used in the calculation of the pipe diametral stiffness

4 Technical requirements

4.1 General

4.1.1 Ductile iron pipes, fittings and accessories

Nominal sizes, pressure classes, thicknesses, lengths and coatings are specified in 4.1.1, 4.2, 4.3.1, 4.3.3, 4.5 and 4.6 respectively. When pipes, fittings and accessories with different pressure classes, lengths and/or coatings and other types of fittings than those given in 8.3 and 8.4, are supplied with reference to this standard, they shall comply with all the other requirements of this standard.

Non-centrifugally cast pipes shall be considered as fittings.

NOTE 1 Other types of fittings include angle branches, tees and tapers with other combinations DN x dn, draining tees, etc.

The standardized nominal sizes DN of pipes and fittings are as follows: 40, 50, 60, 65, 80, 100, 125, 150, 200, 250, 300, 350, 400, 450, 500, 600, 700, 800, 900, 1 000, 1 100, 1 200, 1 400, 1 500, 1 600, 1 800, 2 000.

The allowable pressures of ductile iron pipes and fittings shall be as given in Annex A.

NOTE 2 Annexes B and C give respectively the longitudinal bending resistance and the diametral stiffness of ductile iron pipes.

NOTE 3 When installed and operated under the conditions for which they are designed (see Annexes D, E and F), ductile iron pipes, fittings, accessories and their joints maintain all their functional characteristics over their reasonable economic operating life, due to the constant material properties, to the stability of their cross section and to their design with high safety factors.

4.1.2 Surface condition and repair

Pipes, fittings and accessories shall be free from defects and surface imperfections which can lead to non-compliance with Clauses 4 and 5.

When necessary, pipes and fittings may be repaired, for example by welding, in order to remove surface imperfections and localized defects which do not extend through the entire wall thickness, provided that:

- the repairs are carried out according to the manufacturer's written procedure;
- the repaired pipes and fittings comply with all the requirements of Clauses 4 and 5.

4.1.3 Types of joints and interconnection

4.1.3.1 General

Elastometric gasket materials shall comply with the requirements of EN 681-1, type WA. When materials other than rubber are necessary (e.g. for high temperature flanged joints), they shall comply with the appropriate European Technical Specification or where no European Technical Specification exists, the appropriate International Standard.

4.1.3.2 Flexible joints

Components with flexible joints shall comply with 4.3.2.1 for their spigot external diameter DE and their limit deviations. This offers the possibility of interconnection between components equipped with different types of flexible joints.

The design of the sockets and the gaskets for use with the above spigots shall throughout all possible tolerance combinations:

- ensure leak tightness at minimum compression under shear and/or angular deflection;
- ensure both leak tightness and satisfactory anchorage (restrained joint) under shear and/or angular deflection.

In addition, each type of flexible joint shall be designed to fulfil the performance requirements of Clauses 5 and 7, and in particular in case of interconnexion of components from different suppliers such joints shall meet these performance requirements.

Couplings and flange adaptors manufactured for use with ductile iron pipes and fittings shall meet the performance requirements of flexible joints as detailed in Clauses 5 and 7.

NOTE 1 For interconnection with certain types of joints operating within a different tolerance range on DE, the manufacturer's guidance should be followed as to the means of ensuring adequate joint performance at high pressures (e.g. measurement and selection of external diameter).

NOTE 2 For interconnection with existing pipelines which can have external diameters not in compliance with 4.3.2.1, the manufacturer's guidance should be followed as to the appropriate means of interconnection (e.g. adaptors).

4.1.3.3 Flanged joints

Flanges shall be designed such that they can be attached to flanges whose dimensions and tolerances comply with EN 1092-2. This ensures interconnection between all flanged components (pipes, fittings, valves, etc.) of the same PN and DN and adequate joint performance.

Bolts and nuts shall comply as a minimum with the requirements of EN ISO 4016 and EN ISO 4034, grade 4.6. Where washers are required they shall comply with EN ISO 7091.

Although it does not affect interconnection, the manufacturer shall state whether his products are normally delivered with fixed flanges or adjustable flanges.

Flange gaskets may be one of any type given in EN 1514 (all parts).

4.1.3.4 Pipe saddles

Pipe saddles for service connections manufactured for use with ductile iron pipes shall meet the performance requirements as detailed in Clauses 5 and 7.

4.1.4 Materials in contact with water intended for human consumption

Components of a pipe system include several materials given in this standard. When used under the conditions for which they are designed, in permanent or in temporary contact with water intended for human consumption, the components shall not change the quality of that water to such an extent that it fails to comply with the requirements of national regulations.

For this purpose, reference shall be made to the relevant national regulations and standards, transposing EN standards when available, dealing with the influence of materials on water quality and to the requirements for external systems and components as given in EN 805.

4.2 Pressure class

In accordance with 3.21, the pressure class of a component is defined by a combination of its structural performance and the performance of its non-restrained flexible joint.

Restrained joints may reduce the PFA; in this case the PFA shall be declared by the manufacturer.

Annex A gives the PFA, PMA and PEA of the components and their pressure classes.

4.3 Dimensional requirements

4.3.1 Pipes and fittings thickness

The minimum iron wall thickness of pipes DN 40 to DN 2 000 is given as a function of the nominal size (DN) and pressure class (C) in Tables 16 and 17.

For fittings, the nominal thickness e given in tables and on Figures of Subclauses 8.3 and 8.4 is the nominal thickness corresponding to the main part of the body. The actual thickness at any particular point may be increased to meet localized high stresses depending on the shape of the casting (e.g. at internal radius of bends, at the branch-body junction of tees etc.).

The measurement of the wall thickness shall be in accordance with 6.1.1.

Annex A gives the maximum values of PFA, PMA and PEA.

The limit deviations on the nominal wall thickness of fittings shall be as given in Table 1.

Table 1 — Limit deviations on thickness of fittings

Nominal iron wall thickness e mm	Limit deviations on the nominal wall thickness ^a mm
$\leq 7,0$	- 2,3
$> 7,0$	- (2,3 + 0,001 DN)

^a The lower limit only is given so as to ensure sufficient resistance to internal pressure.

4.3.2 Diameter

4.3.2.1 External diameter

Subclause 8.1 specifies the values of the external diameter DE of the coated spigot ends of pipes and fittings and their maximum allowable limit deviations, when measured using a circumferential tape in accordance with 6.1.2. These limit deviations apply to the spigot ends of all pressure classes of pipes and fittings.

NOTE 1 Certain types of flexible joints operate within a different range of tolerance (see 4.1.3.2).

For $DN \leq 300$, the external diameter of the pipe barrel measured with a circumferential tape shall be such as to allow the assembly of the joint over at least two thirds of the pipe length from the spigot when the pipe needs to be cut on site.

For $DN > 300$, if requested by the customer, the manufacturer shall be able to supply pipes suitable for cutting, allowing the assembly of the joint over at least two thirds of the pipe length from the spigot. Such pipes shall be marked.

In addition, the ovality (see 3.29) of the spigot end of pipes and fittings shall:

- remain within the tolerance on DE (see Tables 16 and 17) for DN 40 to DN 200;
- not exceed 1 % for DN 250 to DN 600 or 2 % for $DN > 600$.

NOTE 2 The manufacturer's guidance should be followed as to the necessity and means of ovality correction; certain types of flexible joints can accept the maximum ovality without a need for spigot re-rounding prior to jointing.

4.3.2.2 Internal diameter

The nominal values of the internal diameter of centrifugally cast pipes, expressed in millimetres, are equal to the numbers indicating their nominal size, DN, and the limit deviations shall be as given in Table 2 which applies to lined pipes.

These limit deviations only apply to pipes with cement mortar lining thicknesses as given in Table 9 and up to the maximum DN given in Table 3 for each pressure class. For greater iron and/or cement mortar lining thicknesses these tolerances do not apply.

NOTE Due to the manufacturing process of ductile iron pipes and their internal linings, internal diameters with the lower limit deviation will only appear locally along the pipe length.

Compliance shall be demonstrated according to 6.1.3 or by calculation from the measurements taken for pipe external diameter, iron wall thickness and lining thickness.

Table 2 — Limit deviation on internal diameter

DN	Limit deviation ^a mm
40 to 1 000	- 10
1 100 to 2 000	- 0,01 DN
^a The lower limit only is given.	

Table 3 — Maximum DN for limit deviations on internal diameter for pressure classes

	Classes < 40	Class 40	Classes > 40
Maximum DN	2 000	600	250

4.3.3 Length

4.3.3.1 Standardized lengths of socket and spigot pipes

Pipes shall be supplied to the standardized lengths given in Table 4.

Table 4 — Standardized lengths of socket and spigot pipes

DN	Standardized lengths, L_u ^a m
40 and 50	3
60 to 600	5 or 5,5 or 6
700 and 800	5,5 or 6 or 7
900 to 1 400	5,5 or 6 or 7 or 8,15
1 500 to 2 000	8,15
^a See 3.27.	

The permissible deviations (see 3.28) on the standardized length L_u of pipes shall be as follows:

- for standardized length 8,15 m \pm 150 mm;
- for all other standardized lengths \pm 100 mm.

Pipes shall be designed to a length taken in the range: standardized length plus or minus the permissible deviation; they shall be manufactured to this design length plus or minus the limit deviations given in Table 7.

The manufacturer shall make the information available as to his design lengths.

The standardized length shall be measured according to 6.1.4 and shall be within the limit deviations given in Table 7.

Of the total number of socket and spigot pipes to be supplied in each diameter, the percentage of shorter pipes shall not exceed 10 %, in which case the length reduction shall be:

- up to 0,15 m for the pipes in which samples have been cut for testing (see 4.4);
- up to 2 m by increments of 0,5 m for DN < 700;
- up to 3 m by increments of 0,1 m for DN ≥ 700.

4.3.3.2 Standardized lengths of flanged pipes

Standardized lengths are given in Table 5. Other lengths are permissible and can be supplied within the manufacturing constraints related to each type of flange pipe.

Table 5 — Standardized lengths of flange pipes

Type of pipe	DN	Standardized lengths L^a m
With cast flanges	40 to 2 000	0,5 or 1 or 2 or 3
With screwed or welded flanges	40 to 600	2 or 3 or 4 or 5
	700 to 1 000	2 or 3 or 4 or 5 or 6
	1 100 to 2 000	4 or 5 or 6 or 7
^a See 3.27.		

4.3.3.3 Standardized lengths of fittings

Fittings shall be supplied to the standardized lengths as given in 8.3 and 8.4.

NOTE Two series of dimensions are shown, the series A corresponding to ISO 2531 and the series B, generally limited up to DN 450.

The permissible deviations (see 3.28) on the standardized length of series A fittings shall be as given in Table 6. No deviation is permitted for the fittings of series B. Fittings shall be designed to a length taken in the range: standardized length plus or minus the permissible deviation; they shall be manufactured to this design length plus or minus the limit deviations given in Table 7.

Table 6 — Permissible deviation on lengths of fittings

Type of fitting	DN	Deviation mm
Flanged sockets	40 to 1 200	± 25
Flanged spigots	1 400 to 2 000	± 35
Collars, tapers		
Tees	40 to 1 200	+ 50/- 25
	1 400 to 2 000	+ 75/- 35

Bends 90° (1/4)	40 to 2 000	± (15 + 0,03 DN)
Bends 45° (1/8)	40 to 2 000	± (10 + 0,025 DN)
Bends 22°30' and 11°15' (1/16 and 1/32)	40 to 1 200	± (10 + 0,02 DN)
	1 400 to 2 000	± (10 + 0,025 DN)

4.3.3.4 Limit deviations on lengths

The limit deviations on lengths shall be as given in Table 7.

Table 7 — Limit deviations on length

Type of castings	Limit deviations mm
Socket and spigot pipes (full length or shortened)	- 30/+ 70
Fittings for socketed joints	± 20
Pipes and fittings for flanged joints	± 10 ^a

^a Smaller limit deviations are possible, but not less than ± 3 mm for DN ≤ 600 and ± 4 mm for DN > 600.

4.3.4 Straightness of pipes

Pipes shall be straight, with a maximum deviation of 0,125 % of their length.

The verification of this requirement is usually carried out by visual inspection, but in case of doubt or in dispute the deviation shall be measured in accordance with 6.2.

4.4 Material characteristics

4.4.1 Tensile properties

Components of ductile iron shall have the tensile properties given in Table 8.

The tensile strength shall be tested in accordance with 6.3.

Table 8 — Tensile properties

Type of casting	Minimum tensile strength, R_m MPa	Minimum elongation after fracture, A %	
	DN 40 to DN 2 000	DN 40 to DN 1 000	DN 1 100 to DN 2 000
Pipes centrifugally cast	420	10	7
Pipes not centrifugally cast, fittings and accessories	420	5	5

The 0,2 % proof stress ($R_{p0,2}$) may be measured. It shall be not less than:

- 270 MPa when $A \geq 12$ % for DN 40 to DN 1 000 or $A \geq 10$ % for DN > 1 000;
- 300 MPa in other cases.

For centrifugally cast pipes of DN 40 to DN 1 000 and having a design minimum wall thickness of 10 mm or greater, the minimum elongation after fracture shall be 7 %.

4.4.2 Hardness

The hardness of the various ductile iron components shall be such that they can be cut, drilled, tapped and/or machined with normal tools. The reference test for hardness shall be the Brinell hardness test in accordance with 6.4.

The Brinell hardness shall not exceed 230 HBW for pipes and 250 HBW for fittings and accessories. For components manufactured by welding, a higher Brinell hardness is allowed in the heat affected zone of the weld.

4.5 Coatings and linings for pipes

4.5.1 General

All pipes shall be delivered with an external coating and an internal lining.

The basic coating specification of pipes shall be with an external metallic zinc coating with finishing layer in accordance with 4.5.2, and an internal lining of cement mortar in accordance with 4.5.3.

The joint areas are generally coated as follows:

- external surface of spigot ends: same as external pipe coating;
- flanges and sockets (face and internal surface): bituminous paint or synthetic resin paint, alone or as a supplement to a primer or zinc coating.

This does not preclude the possibility that for special design reasons the upper limit deviation on the external diameter DE of the coated spigot can be greater than that specified in 8.1, provided that the interconnection of the products is ensured by the joint design.

All finished internal coatings (linings) shall comply with 4.1.4.

Pipes with cast flanges may be coated as fittings (see 4.6).

The maximum fluid temperature may be limited to 35°C for some polymeric coatings. If such coatings are to be used at higher temperatures, additional performance testing should be carried out.

Depending on the external and internal conditions of use, alternative coatings detailed in Annex D may be used.

NOTE Annexes D and E give advice on the field of use for pipes with coatings and linings according to this document.

4.5.2 External coating of zinc with finishing layer

4.5.2.1 General

The external coating of centrifugally cast ductile iron pipes shall comprise a layer of metallic zinc, covered by a finishing layer of a bituminous product or synthetic resin compatible with zinc. Both layers shall be works applied.

The zinc is normally applied on oxide-surfaced pipes after heat treatment; at the manufacturer's option, it may also be applied on blast-cleaned pipes. Prior to application of the zinc, the pipe surface shall be dry and free from rust or non-adhering particles or foreign matter such as oil or grease.

4.5.2.2 Coatings characteristics

The metallic zinc coating shall cover the external surface of the pipe and provide a dense, continuous, uniform layer. It shall be free from such defects as bare patches or lack of adhesion. The uniformity of the coating shall be checked by visual inspection. When measured in accordance with 6.6, the mean mass of zinc per unit area shall be not less than 200g/m². The purity of the zinc used shall be at least 99,99 %.

The finishing layer shall uniformly cover the whole surface of the metallic zinc layer and be free from such defects as bare patches or lack of adhesion. The uniformity of the finishing layer shall be checked by visual inspection. When measured in accordance with 6.7, the mean thickness of the finishing layer shall be not less than 70 µm and the local minimum thickness not less than 50 µm.

4.5.2.3 Repairs

Damage to coatings where the area of total removal of zinc and finishing layer has a width exceeding 5 mm and areas left uncoated (e.g. under test token, see 6.6) shall be repaired.

Repairs shall be carried out by:

- metallic zinc spray complying with 4.5.2.2, or application of zinc-rich paint containing at least 90 % zinc by mass of dry film and with a mean mass of applied paint not less than 220 g/m² and
- application of a finishing layer complying with 4.5.2.2.

4.5.3 Internal lining of cement mortar

4.5.3.1 General

Unless specified in the corresponding European Standard, the internal cement mortar lining of ductile iron pipes shall comply with the following requirements.

The cement mortar lining of ductile iron pipes shall constitute a dense, homogeneous layer covering the total internal surface of the pipe barrel.

Prior to application of the lining, the metal surface shall be free from loose material and oil or grease.

The cement mortar mix shall comprise cement, sand and water. If admixtures are used, they shall comply with 4.1.4, and they shall be declared. The ratio by mass of sand to cement shall not exceed 3,5. At the mixing stage, the ratio by mass of total water to cement depends on the manufacturing process and shall be determined such that the lining is in accordance with 4.5.3.2 and 4.5.3.3.

The cement shall be one of those listed in accordance with EN 197-1. The water used in the mortar mix shall be deemed to comply with *Drinking Water Directive* 98/83/EC. High alumina cement may be used to carry raw water, subject to national regulations, or for specific applications.

After application of the fresh lining, controlled curing shall be carried out so as to provide sufficient hydration to the cement.

The cured lining shall comply with 4.1.4, 4.5.3.2 and 4.5.3.3.

4.5.3.2 Strength of the lining

When measured in accordance with 7.1, the compressive strength of the cement mortar after 28 days of curing shall be not less than 50 MPa.

NOTE The compressive strength of the lining is directly related to other functional properties such as high density, good bond and low porosity.

4.5.3.3 Thickness and surface condition

The nominal thickness of the cement mortar lining and its tolerance shall be as given in Table 9. When measured in accordance with 6.8, the lining thickness shall be within the specified tolerance.

The surface of the cement mortar lining shall be uniform and smooth. Trowel marks, protrusion of sand grains and surface texture inherent to the method of manufacture are acceptable. However, there shall be no recesses or local defects which reduce the thickness to below the minimum value given in Table 9.

Fine crazing and hairline cracks associated with cement rich surfaces may appear in dry linings. Shrinkage cracks inherent to cement-bound materials may also develop in the dry linings. After curing of the lining and under normal storage conditions, the crack width and the radial displacement (disbondment) shall not exceed the values given in Table 9.

Table 9 — Thickness of cement mortar lining

DN	Thickness		Maximum crack width and radial displacement
	Nominal value	Limit deviation ^a	
	mm		mm
40 to 300	4	- 1,5	0,4
350 to 600	5	- 2,0	0,5
700 to 1 200	6	- 2,5	0,6
1 400 to 2 000	9	- 3,0	0,8

^a The lower limit only is given.

Cement mortar linings at pipe ends may have a chamfer of maximum length 20 mm and a maximum height of the lining thickness.

NOTE Storage of pipes and fittings in a hot, dry environment can cause metal expansion and mortar shrinkage which can result in the dry lining developing areas of disbondment and shrinkage cracks exceeding the width given in Table 9. When the lining is re-exposed to water, it will swell by absorption of moisture and the cracks will close to conform to Table 9 and will eventually heal by an autogenous process.

4.5.3.4 Repairs

Repairs to areas of damaged linings shall be carried out by the use of either cement mortar (see 4.5.3.1) or a compatible polymer mortar; application may be by hand held implement.

Prior to the application of the repair mortar, the damaged area shall be cut back to the sound lining or to the metal surface and all loose material shall be removed. After completion of the repair, the cement lining shall comply with 4.5.3.1, 4.5.3.2, 4.5.3.3, and 4.1.4.

4.6 Coatings for fittings and accessories

4.6.1 General

All fittings, accessories and pipes not centrifugally cast shall be delivered externally and internally coated either by a paint coating in conformity with 4.6.2 or by an epoxy coating in conformity with EN 14901; fittings may also receive an internal lining of cement mortar conforming with 4.5.3, machine or hand applied, as a supplement to or as a replacement of the above paint coating.

All finished internal linings shall comply with 4.1.4.

Depending on the external and internal conditions of use, alternative coatings detailed in Annex D may be used.

NOTE Annexes D and E give advice on the field of use for fittings with coatings and linings according to this document.

Parts of accessories made from metal other than ductile iron shall have an appropriate corrosion resistance. The corrosion resistance may be attained from the material itself or a suitable coating protection system.

4.6.2 Paint coating

4.6.2.1 General

For components the coating material shall be a bitumen or synthetic resin base. Appropriate additives (such as solvents, inorganic fillers, etc.) to allow easy application and drying are permitted. Prior to application of the coating, the casting surface shall be dry, free from rust or non-adhering particles or foreign matter such as oil or grease. The coating shall be works-applied.

4.6.2.2 Coating characteristics

The coating shall uniformly cover the whole surface of the casting and have a smooth regular appearance. Drying shall be sufficient to ensure that it will not stick to adjacent coated pieces.

When measured in accordance with 6.7, the mean thickness of the coating shall be not less than 70 μm and the local minimum thickness shall be not less than 50 μm .

4.7 Marking of pipes, fittings and accessories

4.7.1 Pipes and fittings

All pipes and fittings shall be legibly and durably marked and shall bear at least the following information:

- the manufacturer's name or mark;
- the identification of the year of manufacture;
- the identification as ductile iron;
- the DN;
- the PN rating of flanges for flange components;
- the reference to this European Standard, i.e. EN 545;
- the pressure class designation of centrifugally cast pipes.

The first five markings given above shall be cast-on or cold stamped; the other markings can be applied by any method, e.g. painted on the casting.

4.7.2 Accessories

All accessories shall be legibly and durably marked and shall bear at least the following information:

- the manufacturer's name or mark;
- the identification of the year of manufacture;
- the DN;
- the PN rating of flanges for flange components;
- the reference to this European Standard, i.e. EN 545;
- the PFA for couplings and saddles.

These markings should be cast on or cold stamped but where impracticable can be applied by painting or labelling or attached to the packaging.

4.8 Leak tightness

Components and their joints shall be designed to be leak tight at their allowable test pressure (PEA):

- components shall be tested in accordance with 6.5 and shall exhibit no visible leakage, sweating or any other sign of failure;
- joints shall comply with the performance requirements of Clause 5.

5 Performance requirements for joints and pipe saddles

5.1 General

In order to ensure their fitness for purpose in the field of water supply, all the joints and pipe saddles shall fulfil the relevant performance requirements of Clause 5.

One end of a coupling is classified as the joint as long as both ends are to the same design. Where the joint design for a coupling is the same as a flange adaptor, testing need only be carried out on either coupling or flange adaptor.

There shall be a performance test for at least one DN for each of the groupings given in Table 10. One DN is representative of a grouping when the performances are based on the same design parameters throughout the size range. If a grouping covers products of different designs and/or manufactured by different processes, the grouping shall be sub-divided.

Table 10 — DN groupings for performance tests

DN groupings	40 to 250	300 to 600	700 to 1 000	1 100 to 2 000
Preferred DN in each grouping	200	400	800	1 600

For restrained joints, the PFA is generally less than the pressure class of the pipe and therefore DN groupings of table 10 may include more than one pipe pressure class; as such, one performance test shall be carried out for each DN sub-group with the same pipe pressure class.

When flanges are involved, there shall be a performance test for at least one PN for each of the groupings given in Table 10. The PN to be tested is the highest PN existing for each flange design. One PN is representative of a grouping when the performances are based on the same design parameters throughout the size range. If a grouping covers products of different designs and/or manufactured by different processes, the grouping shall be sub-divided.

If for a manufacturer a grouping contains only one DN or PN, this DN or this PN may be considered as part of the adjacent grouping provided that it is of identical design and manufactured by the same process.

5.2 Flexible joints

5.2.1 General

All joints shall be designed to be fully flexible; consequently, the allowable angular deflection declared by the manufacturer shall be not less than:

- 3°30' for DN 40 to DN 300;

- 2°30' for DN 350 to DN 600;
- 1°30' for DN 700 to DN 2 000.

All joints shall be designed to provide axial movement; the allowable withdrawal shall be declared by the manufacturer.

NOTE This permits the installed pipeline to accommodate ground movements and/or thermal effects without incurring additional stresses.

5.2.2 Test conditions

All joint designs shall be performance tested under the most unfavourable applicable conditions of tolerance and joint movement as given below:

- a) joint of maximum annulus (see 5.2.3.1) aligned, withdrawn to the allowable value to be declared by the manufacturer, and subject to shear (see 5.2.3.3);
- b) joint of maximum annulus (see 5.2.3.1) deflected to the allowable value to be declared by the manufacturer (see 5.2.1).

The joints shall exhibit no visible leakage, and the pipes or the fittings being tested with the joints shall not exhibit any detrimental damage, when subjected to the tests given in Table 11.

Table 11 — Performance tests for joints

Test	Test requirements	Test conditions	Test method
1) Positive internal hydrostatic pressure	Test pressure: (1,5 PFA + 5) bar	Joint of maximum annulus, aligned and withdrawn, with shear load	In accordance with 7.2.2
	Test duration: 2 h No visible leakage	Joint of maximum annulus, deflected	
2) Negative internal pressure	Test pressure: - 0,9 bar ^a	Joint of maximum annulus, aligned and withdrawn, with shear load	In accordance with 7.2.3
	Test duration: 2 h Maximum pressure change during test period: 0,09 bar	Joint of maximum annulus, deflected	
3) Positive external hydrostatic pressure	Test pressure: 2 bar Test duration: 2 h No visible leakage	Joint of maximum annulus, aligned, with shear load	In accordance with 7.2.4
4) Cyclic internal hydraulic pressure	24 000 cycles Test pressure: between PMA and (PMA – 5) bar No visible leakage	Joint of maximum annulus, aligned and withdrawn, with shear load	In accordance with 7.2.5
^a 0,9 bar below atmospheric pressure (approximately 0,1 bar absolute pressure).			

Test 3) (positive external pressure) may be omitted for mechanical joints, provided they have been performance tested according to Tests 1) and 2).

5.2.3 Test parameters

5.2.3.1 Annulus

All joints shall be performance tested at the extremes of manufacturing tolerance such that the annular gap between the sealing surfaces of the socket and of the spigot is equal to the maximum design value plus 0 %, minus 5 %. It is permissible to machine socket internal surfaces to achieve the required annulus for the performance test even though the resultant diameter can be slightly outside the normal manufacturing tolerance.

5.2.3.2 Pipe thickness

All joints shall be performance tested with a spigot having an average iron wall thickness equal to the specified minimum value for the pipe for which the joint is designed plus 10 %, minus 0 %. The average iron wall thickness shall be the mean of a total of at least 12 measurements taken on 6 lines (at approximately 60° around the circumference) over a distance of 2 x DN, in millimetres, from the spigot face (with a maximum of 1 m). It is permissible to machine the spigot of the test pipe in the bore to achieve the required thickness.

5.2.3.3 Shear

All joints shall be performance tested with a resultant shear force across the joints of not less than 50 x DN, in newtons, taking into account the weight of the pipe and of its contents and the geometry of the test assembly (see 7.2.2).

5.3 Restrained flexible joints

All restrained joints shall be designed to be at least semi-flexible; the allowable angular deflection declared by the manufacturer shall be not less than half of the value shown in 5.2.1.

All restrained joint designs shall be performance tested in accordance with 7.2 following the requirements of 5.2.2 and 5.2.3, except that:

- the withdrawal condition of 5.2.2 a) shall not apply;
- there shall be no external axial restraint in positive internal pressure tests so that the joint is subjected to the full end thrust.

During the positive internal pressure tests, the axial movement shall reach a stable value and cease.

When the restraining mechanism and the sealing component of a restrained joint are independent, such a joint does not need to be subjected to Test 2 and Test 3 of 5.2.2 if the unrestrained version of the joint has passed these tests.

5.4 Flanged joints as cast, screwed, welded and adjustable

In order to demonstrate their strength and leak tightness in service conditions, flanged joints shall be subjected to a performance test. When tested in accordance with 7.3, they shall show no visible leakage under the combined effects of a hydrostatic internal pressure and of a bending moment given in Table 12, where:

- the pressure is $(1,5 PN + 5)$ bar;
- the relevant bending moment is obtained by addition of the bending moments due to the weight of the components and of the water in the test assembly and to a possible external load calculated as a function of the length of the unsupported span of the testing arrangement (see 7.3).

A performance test shall be carried out on each type of flange joint available from the manufacturer in accordance with Table 10.

NOTE The bending moments given in Table 12 are equal to those resulting from the weight of the pipes and of the water over an unsupported pipe length L between simple supports, with:

- $L = 8$ m for $DN \leq 250$;
- $L = 12$ m for $DN \geq 300$.

Table 12 — Bending moments for flange joint performance tests

DN	Bending moment kN·m	DN	Bending moment kN·m
40	0,7	500	63
50	0,9	600	87
60	1,3	700	116
65	1,4	800	146
80	1,8	900	181
100	2,3	1 000	222
125	2,9	1 100	265
150	4,0	1 200	313
200	6,0	1 400	423
250	8,6	1 500	475
300	26,0	1 600	548
350	33,8	1 800	625
400	42	2 000	770
450	51		

5.5 Pipe saddles

5.5.1 Test conditions

All pipe saddle designs shall be performance tested under the most unfavourable conditions of tolerance as given below:

- a) with the outlet vertical and fitted with a service valve, saddle assembled on the pipe in accordance with the supplier's instructions, saddle joint of maximum annulus (see 5.5.2), apply a torque, in Nm, to the service valve equal to three times the DN of the largest service valve for the saddle, with a minimum of 100 Nm;
- b) with the outlet horizontal and fitted with a service valve, saddle assembled on the pipe in accordance with the supplier's instructions, saddle joint of maximum annulus (see 5.5.2), apply a minimum vertical force of 500 N to the square cap of the horizontal valve.

When subjected to the tests given in Table 13, the saddle joint shall exhibit no visible leakage, the saddles shall not exhibit any detrimental damage and their movement relative to the pipe shall not exceed 3 mm.

5.5.2 Annulus

All saddles shall be performance tested at the extremes of manufacturing tolerance such that the annular gap between the sealing surfaces of saddle and of the barrel of the pipe is equal to the maximum design value plus 0 %, minus 5 %. It is permissible to machine saddle internal surfaces to achieve the required annulus for the performance test even though the resulting dimension of the saddle may be slightly outside the normal manufacturing tolerance.

Table 13 — Performance tests for pipe saddles

Test	Test requirements	Test conditions	Test method
1) Positive internal hydrostatic pressure	Test pressure: (1,5 PFA + 5) bar Test duration: 2 h No visible leakage	Joint maximum annulus	In accordance with 7.4.1
2) Negative internal pressure	Test pressure: - 0,9 bar ^a Test duration: 2 h Maximum pressure change during test period: 0,09 bar	Joint maximum annulus	In accordance with 7.4.2
^a 0,9 bar below atmospheric pressure (approximately 0,1 bar absolute pressure).			

6 Test methods

6.1 Pipe dimensions

6.1.1 Wall thickness

Pipe wall thickness compliance shall be demonstrated by the manufacturer. He may use a combination of various means, e.g. direct wall thickness measurement, mechanical or ultrasonic measurement.

The iron wall thickness shall be measured by suitable equipment having an error limit $\pm 0,1$ mm.

6.1.2 External diameter

Socket and spigot pipes shall be measured at their spigot end by means of a circumferential tape or controlled by pass/fail gauges. In addition, they shall be visually inspected for compliance with the spigot allowable ovality and, in case of doubt; the maximum and minimum spigot axes shall be measured by suitable equipment or controlled by pass/fail gauges.

6.1.3 Internal diameter

The internal diameter of the lined pipes shall be measured by means of suitable equipment:

either

- a) two measurements shall be taken at right angles, at a cross section 200 mm or more from the end face; the mean value of these two measurements may then be calculated;

or

- b) a system of pass/fail gauges shall be passed along the bore of the pipe.

6.1.4 Length

The length of socket and spigot pipes shall be measured by suitable equipment:

- on one pipe from the first batch of pipes cast from a new mould, for as-cast pipes;
- on the first pipe, for pipes which are systematically cut to a pre-set length.

6.2 Straightness of pipes

The pipe shall be rolled on two gantries or rotated around its axis on rollers, which in each case are separated by not less than two thirds of the standardized pipe length.

The point of maximum deviation from the straight axis shall be determined and the deviation measured at that point.

6.3 Tensile testing of ductile iron components

6.3.1 Samples

The thickness of the sample and the diameter of the test bar shall be as given in Table 14.

6.3.1.1 Centrifugally cast pipes

A sample shall be cut from the spigot of the pipe. This sample may be cut parallel with or perpendicular to the pipe axis, but in case of dispute the parallel with axis sample shall be used.

6.3.1.2 Pipes not centrifugally cast, fittings and accessories

At the manufacturer's option, samples shall be either cast integrally with the castings or cast separately. In the latter case they shall be cast from the same metal as that used for the castings. If the castings are subjected to heat treatment, the samples shall be subjected to the same heat treatment cycle.

6.3.2 Preparation of test bar

A test bar shall be machined from each sample to be representative of the metal at the mid thickness of the sample, with a cylindrical part having the diameter given in Table 14.

The test bar shall have a gauge length equal to at least five times the nominal test bar diameter. The ends of the test bar shall be such that they will fit the testing machine.

The surface roughness profile of the cylindrical part of the test bar shall be such that $R_z \leq 6,3$.

If the specified diameter of the test bar is greater than 60 % of the measured minimum thickness of the sample, it is allowed to machine a test bar with a smaller diameter, or to cut another sample in a thicker part of the pipe.

Table 14 — Dimensions of test bar

Type of casting	Nominal diameter of the test bar mm	Limit deviations on diameter mm	Tolerance on shape ^a mm
Centrifugally cast pipes, with a wall thickness (mm) of:			
a) less than 6	2,5		
b) 6 up to but not including 8	3,5	± 0,06	0,03
c) 8 up to but not including 12	5,0		
d) 12 and over	6,0		
Pipes not centrifugally cast, fittings and accessories:			
a) integrally cast samples	5,0	± 0,06	0,03
b) separately cast samples:			
1) sample thickness 12,5 mm for casting thickness less than 12 mm	6,0	± 0,06	0,03
2) sample thickness 25 mm for casting thickness 12 mm and over	12,0 or 14,0	± 0,09	0,04
a Maximum difference between the smallest and the largest measured diameter of the test bar.			

The tensile strength shall be calculated either from the nominal diameter of the test bar when it has been machined to fulfil all the tolerances given in Table 14, or, if it is not the case, from the actual diameter of the test bar measured before the test; the actual diameter shall be measured using a measuring device having an error limit $\leq 0,5\%$ and shall be within $\pm 10\%$ of the nominal diameter.

6.3.3 Apparatus and test method

The tensile test shall be carried out in accordance to EN ISO 6892-1.

6.3.4 Test results

Test results shall comply with Table 8. If they do not comply, the manufacturer shall:

- a) in the case where the metal does not achieve the required mechanical properties, investigate the reason and ensure that all castings in the batch are either re-heat treated or rejected; castings which have been re-heat treated are then re-tested in accordance with 6.3;
- b) in the case of a defect in the test bar, carry out a further test; if it passes, the batch is accepted; if not, the manufacturer has the option to proceed as in a) above.

The manufacturer may limit the amount of rejection by making tests until the rejected batch of castings is bracketed, in order of manufacture, by a successful test at each end of the interval in question.

6.4 Brinell hardness of ductile iron components

When Brinell hardness tests are carried out (see 4.4.2), they shall be performed either on the casting in dispute or on a sample cut from the casting. The surface to be tested shall be suitably prepared by local grinding to ensure a flat surface and the test shall be carried out in accordance with EN ISO 6506-1 using a ball of 2,5 mm or 5 mm or 10 mm diameter.

6.5 Works leak tightness test for pipes and fittings

6.5.1 General

Pipes and fittings shall be tested in accordance with 6.5.2 and 6.5.3 respectively. The test shall be carried out on all pipes and fittings before the application of their external and internal coatings, except for the metallic zinc coating of pipes which may be applied before the test.

The test apparatus shall be suitable for applying the specified test pressures to the pipes and/or fittings. It shall be equipped with an industrial pressure gauge with an error limit $\pm 3\%$.

6.5.2 Centrifugally cast pipes

The internal hydrostatic pressure shall be raised steadily until it reaches the works hydrostatic test pressure equal to the pressure class up to Class 50 and limited to 50 bar for classes above Class 50, which is maintained for a sufficient time to allow visual inspection of the pipe barrel. The total duration of the pressure cycle shall be not less than 15 s, including 10 s at test pressure.

6.5.3 Pipes not centrifugally cast, fittings and accessories

At the manufacturer's option, they shall be submitted to a hydrostatic pressure test or to an air test.

When the hydrostatic pressure test is carried out, it shall be in the same way as for centrifugally cast pipes (see 6.5.2), except for the test pressures which shall be as given in Table 15.

Table 15 — Works test pressure for pipes not centrifugally cast, fittings and accessories

DN	Pipes not centrifugally cast, fittings and accessories ^a bar
40 to 300	25 ^b
350 to 600	16
700 to 2 000	10

^a The works hydrostatic test pressure is less than for pipes because of the difficulty providing sufficient restraint to high internal pressures during test.

^b 16 bar for pipes and fittings with PN 10 flanges.

When the air test is carried out, it shall be with an internal pressure of at least 1 bar and a visual inspection time not less than 10 s; for leak detection, the castings shall be either uniformly coated on their external surface by a suitable foaming agent or submerged in water.

6.6 Zinc mass

A rectangular token of known weight per unit area shall be attached longitudinally along the axis of the pipe before passing it through the coating equipment. After zinc coating and trimming, the size of the token shall be 500 mm x 50 mm. It shall be weighed on a scale having an error limit $\pm 0,01$ g.

The mean mass M of zinc per unit area shall be determined from the mass difference before and after coating.

$$M = C \left(\frac{M_2 - M_1}{A} \right)$$

where:

- M is the mean mass of zinc in grammes per square metre;
- M_1 and M_2 are the masses of the sample token, in grammes, before and after coating;
- C is the predetermined correction factor, taking account of the nature of the token and of the difference in surface roughness between the token and the iron pipe;
- A is the actual area of the trimmed token, in square metres.

The value of C is generally between 1 and 1,2, and shall be given in the manufacturer's FPC procedures.

The uniformity of the coating shall be checked by visual inspection of the token; in the event of a lack of uniformity, 50 mm x 50 mm pieces shall be cut from the token in the lighter mass zones and the mean mass of zinc determined on each piece by mass difference.

Alternatively the mass of zinc per unit area can be measured directly on the coated pipe by any method having proven correlation with the reference method described above, e.g. X-ray fluorescence or chemical analysis.

6.7 Thickness of paint coatings

The dry film thickness of paint coatings shall be measured by one of the three following methods:

- directly on the casting by means of suitable gauges, e.g. magnetic, or by using a 'wet film' thickness gauge where a correlation between wet film thickness and dry film thickness can be demonstrated, or
- indirectly on a token which is attached to the casting before coating and is used after coating to measure the dry film thickness by mechanical means, e.g. micrometer, or by a weight method similar to 6.6, or
- indirectly on a test plate made of steel or of ductile iron, which is coated by the same process as the castings to be controlled.

For each casting to be controlled, at least five measurements shall be taken (either on the casting or on the token or on a test plate). The mean thickness is the average of all the measurements taken and the local minimum thickness is the lowest value of all the measurements taken. The manufacturer shall record the method used in his documented FPC procedures.

6.8 Thickness of cement mortar lining

During manufacture, the thickness shall be measured on the freshly applied lining by a spear having a diameter of 1,5 mm or less and controlled on the finished hardened lining by means of a suitable gauge, e.g. magnetic.

For pipes, the measurements shall be taken approximately 200 mm from the end face. The manufacturer's process control system shall specify the frequency of this test.

7 Performance test methods

7.1 Compressive strength of the cement mortar lining

The compressive strength shall be determined by a performance test in accordance with EN 196-1, except that:

- the sand and the cement used for the prism samples are identical with those used for the mortar before application of the lining and the water shall conform to the requirements of 4.5.3.1;
- the sand/cement ratio used for the prism samples is equal to that used for the mortar before application of the lining;
- the water/cement ratio used for the prism samples is equal to that of the lining immediately after application to the pipe wall;
- the test samples are prepared using either an impact table (in accordance with EN 196-1) or a vibrating table (time 120 ± 5 s, frequency of vibrating mass 50 to 65 Hz) when the water/cement ratio is below 0,35.

NOTE This takes into account the influence of the centrifugal spinning process which allows expelling the excess water.

7.2 Leak tightness of flexible joints

7.2.1 General

The tests shall be carried out on pipe joints, and also separately on joints of fittings and other components if their socket dimensions which influence joint leak tightness differ from those of the spun pipe socket. For such tests a flanged socket (see 8.3.2) shall be bolted to a flanged pipe of sufficient length to satisfy the requirements of 7.2.2.

Tests shall be carried out on both unrestrained and restrained joints as necessary.

The short and long term characteristics of the rubber for the gaskets shall be in compliance with EN 681-1, type WA.

The relevant designs of socket and gasket throughout all possible tolerance combinations (see 5.2.3) shall:

- ensure leak tightness at minimum compression under shear and/or angular deflection;
- ensure both leak tightness and satisfactory anchorage (restrained joint) under shear and/or angular deflection.

The following joint parameters are considered vital to the performance of a joint and shall be checked to be in accordance with the relevant specifications:

- spigot wall thickness;
- spigot external diameter;
- socket functional internal diameters;
- socket depth;
- gasket diameter, thicknesses and hardness.

7.2.2 Leak tightness of flexible joints to positive internal pressure

The test shall be carried out on an assembled joint comprising two pipe sections, each at least 1 m long (see Figure 1).

For couplings only one of the joints shall be tested; the joint not involved in the test shall be fixed to avoid coupling rotation under the shear load.

For flange adaptors, only one pipe, at least 1 m long, shall be used; the flange shall be capped off using a suitable blank flange. The flange/blank flange junction shall bear on a flat support.

The test apparatus shall be capable of providing suitable end and lateral restraints whether the joint is in the aligned position, or deflected, or subjected to a shear load. It shall be equipped with a pressure gauge with an accuracy $\leq 3\%$ in relation to the range of measured pressures.

The vertical force W shall be applied to the spigot by means of a V shaped block with an angle of $120 \pm 10^\circ$, located at approximately $0,5 DN$ in millimetres or 200 mm from the socket face, whichever is the largest; the socket shall bear on a flat support. The vertical force W shall be such that the resultant shear force F across the joint is equal to the value specified in 5.2.3.3, taking into account the mass M of the pipe and its contents and the geometry of the test assembly:

$$W = \frac{F \cdot c - M(c - b)}{c - a}$$

where:

a , b and c are as shown in Figure 1.

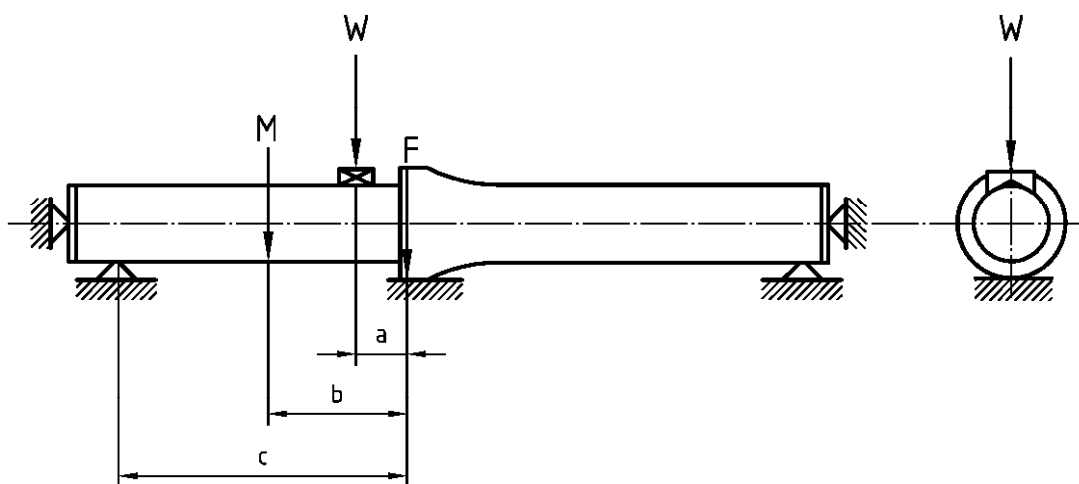

Figure 1 — Leak tightness test of joints (internal pressure)

The test assembly shall be filled with water and suitably vented of air. The pressure shall be raised steadily until it reaches the test pressure given in 5.2.2; the rate of pressure increase shall not exceed 2 bar/s. The pressure shall be kept at least equal to the test pressure for at least 2 h during which the joint shall be thoroughly inspected every 15 min.

All necessary safety precautions should be taken for the duration of the pressure test.

For a restrained joint, the test assembly, the test apparatus and the test procedure shall be identical except that there shall be no end restraint, so that the axial thrust is taken by the restrained joint under test. In addition, possible axial movement of the spigot shall be measured every 15 min.

7.2.3 Leak tightness of flexible joints to negative internal pressure

The test assembly and test apparatus shall be as given in 7.2.2, with the pipe sections axially restrained to prevent them moving towards each other.

The test assembly shall be empty of water and shall be evacuated to a negative internal pressure of 0,9 bar (see 5.2.2) and then isolated from the vacuum pump. The test assembly shall be left under vacuum for at least 2 h during which the pressure shall not have changed by more than 0,09 bar. The test shall begin at a temperature between 5 °C and 40 °C. The temperature of the test assembly shall not vary by more than 10 °C for the duration of the test.

For a restrained joint, the test assembly, the test apparatus and the test procedure are identical.

7.2.4 Leak tightness of flexible push-in joints to positive external pressure

The test assembly shall comprise two joints made with two pipe sockets welded together and one double-spigot piece (see Figure 2); it creates an annular chamber which allows testing one joint under internal pressure and one joint under external pressure.

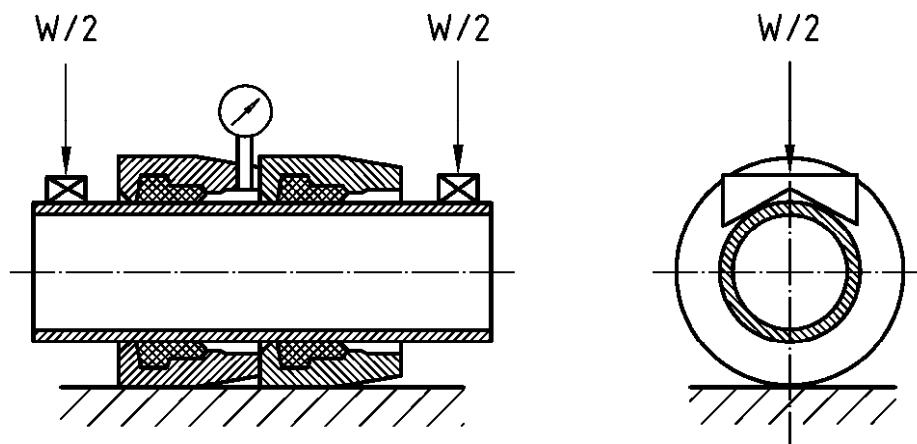

Figure 2 — Leak tightness test of joints (external pressure)

The test assembly shall be subjected to a vertical force W equal to the shear force F defined in 5.2.3.3; one half of this load shall be applied to the spigot on each side of the test assembly, by means of a V shaped block with an angle of $120 \pm 10^\circ$, located at approximately 0,5 DN in millimetres or 200 mm from the ends of the sockets, whichever is the largest; the sockets shall bear on a flat support.

The test assembly shall be filled with water and suitably vented of air. The pressure shall be steadily increased until it reaches the test pressure of 2 bar. The latter shall be kept constant within $\pm 0,1$ bar for at least 2 h during which the internal side of the joint subjected to external pressure shall be thoroughly inspected every 15 min.

For a restrained joint, the test assembly, the test apparatus and the test procedure are identical.

7.2.5 Leak tightness of flexible joints to dynamic internal pressure

The test assembly and test apparatus shall be as given in 7.2.2. The test assembly shall be filled with water and suitably vented of air.

The pressure shall be steadily increased up to PMA, the allowable maximum operating pressure of the joint, and then automatically monitored according to the following pressure cycle:

- a) steady pressure reduction to (PMA – 5) bar;

- b) maintain (PMA – 5) bar for at least 5 s;
- c) steady pressure increase to PMA;
- d) maintain PMA for at least 5 s.

The pressure may vary during steps b) and d) either side of the specified pressure, but the difference between the mean pressure in b) and the mean pressure in d) shall be at least 5 bar.

The number of cycles shall be recorded and the test stopped automatically in the occurrence of a failure of the joint.

For a restrained joint, the test assembly, the test apparatus and the test procedure are identical, except that there shall be no end restraint so that the axial thrust is taken by the restrained joint under test. In addition, any axial movement at the spigot shall be measured every 15 min.

All necessary safety precautions should be taken for the duration of the pressure test.

7.3 Leak tightness and mechanical resistance of flanged joints

The test assembly shall comprise two pipes or fittings with identical flanges, assembled together by means of the gasket and bolts defined by the manufacturer. Both ends of the test assembly shall be equipped with blank flanges. The bolts shall be tightened to the torque given by the manufacturer for the maximum PN of the DN under test. The bolt material grade, when not defined, shall be grade 4.6 of EN ISO 4016.

The test assembly shall be placed on two simple supports (see Figure 3) such that the assembled flanged joint is positioned at mid span. The minimum length of unsupported span shall be either 6 DN in millimetres or 4 000 mm, whichever is the smallest. This length can be obtained by a combination of pipes or fittings, but only the tested joint at mid span shall be considered.

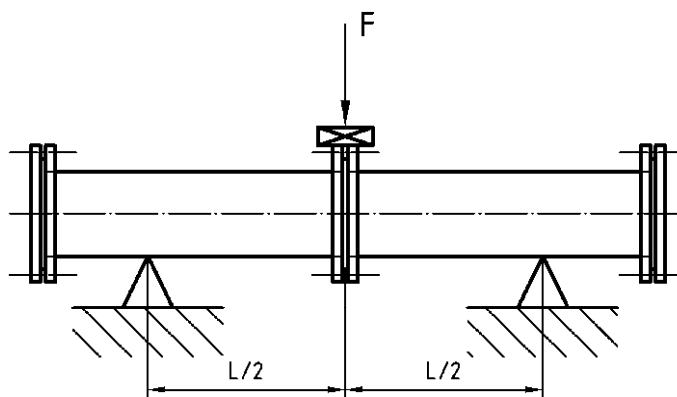

Figure 3 — Strength and leak tightness test for flanged joints

The test assembly shall be filled with water and suitably vented of air. The pressure shall be raised steadily until it reaches the test pressure given in 5.4. The external load F shall be applied to the assembled flanged joint by means of a flat plate, in a direction perpendicular to the axis of the test assembly, so as to cause the bending moment given in Table 12.

The internal pressure and the external load shall be kept constant for 2 h during which the flanged joint shall be thoroughly inspected.

All necessary safety precautions should be taken for the duration of the pressure test.

7.4 Leak tightness and mechanical resistance of pipe saddles

7.4.1 Positive internal pressure

The test shall be carried out on an assembly at least 1 m long (see Figure 4). The pipe ends shall be suitably capped and restrained to withstand the internal positive pressure.

The saddle shall be assembled such that the outlet is vertical and prior to pressurisation the relevant torque shall be applied to the saddle service valve (see 5.5.1)

The test assembly shall be filled with water and suitably vented of air. The pressure shall be raised steadily until it reaches the test pressure given in Table 15. The test pressure shall be kept constant within $\pm 0,5$ bar for at least 2 h during which the saddle shall be inspected every 15 min.

The test shall be repeated with the saddle outlet horizontal and prior to pressurisation the relevant load shall be applied to the saddle service valve cap (see 5.5.1), the pipe being fixed in rotation.

Saddles designed for use in only one direction (vertical or horizontal) shall only be tested in that orientation.

All necessary safety precautions should be taken for the duration of the test.

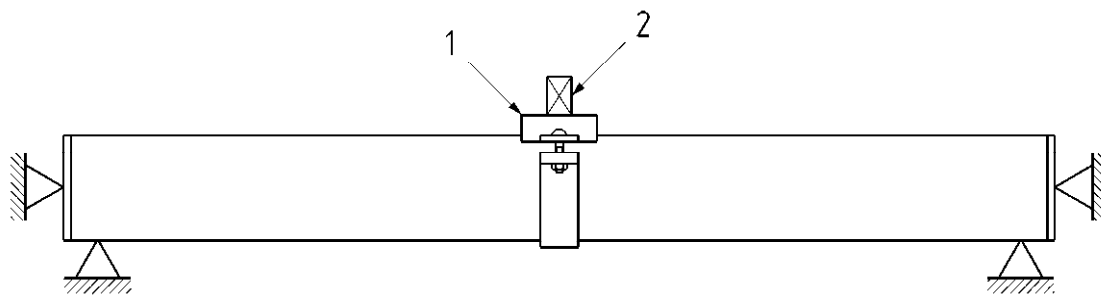

Key

- 1) Saddle
- 2) Valve

Figure 4 — Leak tightness test for pipe saddles

7.4.2 Negative internal pressure

The test assembly and test apparatus shall be as given in 7.4.1, with the pipe ends capped.

The saddle shall be assembled such that the outlet is vertical and prior to pressurisation the relevant torque shall be applied to the saddle service valve (see 5.5.1).

The test assembly shall be empty of water and shall be evacuated to a negative internal pressure of 0.9 bar (see Table 13) and then isolated from the vacuum pump. The test assembly shall be left under vacuum for at least 2 h during which the pressure shall not have changed by more than 0,09 bar.

The test shall be repeated with the saddle outlet horizontal and prior to pressurisation the relevant load shall be applied to the saddle service valve cap (see 5.5.1), the pipe being fixed in rotation.

Saddles designed for use in only one direction (vertical or horizontal) shall only be tested in that orientation.

8 Tables of dimensions

8.1 Socket and spigot pipes

The dimensions of socket and spigot pipes shall be as given in Tables 16 and 17. The values of L_u are given in Table 4. For external and internal coatings, see 4.5.

The values of DE and their tolerances also apply to the spigot ends of fittings (see 4.3.2.1).

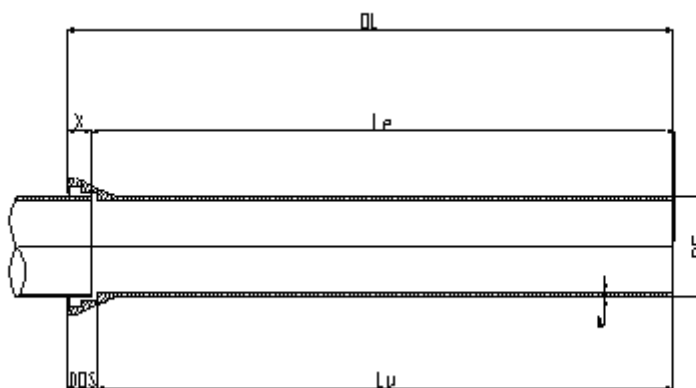

Key

OL = overall length in metres

X = maximum insertion depth as given by the manufacturer in metres

L_e = $OL - X$, which is the laying length, in metres

DOS = Depth of socket, in metres

L_u = $OL - DOS$, which is the standardized length in metres

e = wall thickness in millimetres

DE = nominal external diameter of spigot in millimetres

Figure 5 — Socket and spigot pipes

Table 16 — Dimensions of pipes of preferred pressure classes

DN	External diameter DE		Pressure class	Minimum wall thickness <i>e</i>
	mm			
-	Nominal	Limit deviations	-	-
40	56	+ 1/ - 1,2	40	3,0
50	66	+ 1/ - 1,2	40	3,0
60	77	+ 1/ - 1,2	40	3,0
65	82	+ 1/ - 1,2	40	3,0
80	98	+ 1/ - 2,7	40	3,0
100	118	+ 1/ - 2,8	40	3,0
125	144	+ 1/ - 2,8	40	3,0
150	170	+ 1/ - 2,9	40	3,0
200	222	+ 1/ - 3,0	40	3,1
250	274	+ 1/ - 3,1	40	3,9
300	326	+ 1/ - 3,3	40	4,6
350	378	+ 1/ - 3,4	30	4,7
400	429	+ 1/ - 3,5	30	4,8
450	480	+ 1/ - 3,6	30	5,1
500	532	+ 1/ - 3,8	30	5,6
600	635	+ 1/ - 4,0	30	6,7
700	738	+ 1/ - 4,3	25	6,8
800	842	+ 1/ - 4,5	25	7,5
900	945	+ 1/ - 4,8	25	8,4
1 000	1 048	+ 1/ - 5,0	25	9,3
1 100	1 152	+ 1/ - 6,0	25	10,2
1 200	1 255	+ 1/ - 5,8	25	11,1
1 400	1 462	+ 1/ - 6,6	25	12,9
1 500	1 565	+ 1/ - 7,0	25	13,9
1 600	1 668	+ 1/ - 7,4	25	14,8
1 800	1 875	+ 1/ - 8,2	25	16,6
2 000	2 082	+ 1/ - 9,0	25	18,4

NOTE The preferred pipe pressure classes cover products intended for all usual applications

Table 17 — Dimensions of pipes

DN	External diameter DE		Minimum wall thickness <i>e</i>						
	mm		mm						
	Nominal	Limit deviations	Class 20	Class 25	Class 30	Class 40	Class 50	Class 64	Class 100
40	56	+ 1/ - 1,2				3,0	3,5	4,0	4,7
50	66	+ 1/ - 1,2				3,0	3,5	4,0	4,7
60	77	+ 1/ - 1,2				3,0	3,5	4,0	4,7
65	82	+ 1/ - 1,2				3,0	3,5	4,0	4,7
80	98	+ 1/ - 2,7				3,0	3,5	4,0	4,7
100	118	+ 1/ - 2,8				3,0	3,5	4,0	4,7
125	144	+ 1/ - 2,8				3,0	3,5	4,0	5,0
150	170	+ 1/ - 2,9				3,0	3,5	4,0	5,9
200	222	+ 1/ - 3,0				3,1	3,9	5,0	7,7
250	274	+ 1/ - 3,1				3,9	4,8	6,1	9,5
300	326	+ 1/ - 3,3				4,6	5,7	7,3	11,2
350	378	+ 1/ - 3,4			4,7	5,3	6,6	8,5	13,0
400	429	+ 1/ - 3,5			4,8	6,0	7,5	9,6	14,8
450	480	+ 1/ - 3,6			5,1	6,8	8,4	10,7	16,6
500	532	+ 1/ - 3,8			5,6	7,5	9,3	11,9	18,3
600	635	+ 1/ - 4,0			6,7	8,9	11,1	14,2	21,9
700	738	+ 1/ - 4,3		6,8	7,8	10,4	13,0	16,5	
800	842	+ 1/ - 4,5		7,5	8,9	11,9	14,8	18,8	
900	945	+ 1/ - 4,8		8,4	10,0	13,3	16,6		
1 000	1 048	+ 1/ - 5,0		9,3	11,1	14,8	18,4		
1 100	1 152	+ 1/ - 6,0	8,2	10,2	12,2	16,2	20,2		
1 200	1 255	+ 1/ - 5,8	8,9	11,1	13,3	17,7	22,0		
1 400	1 462	+ 1/ - 6,6	10,4	12,9	15,5				
1 500	1 565	+ 1/ - 7,0	11,1	13,9	16,6				
1 600	1 668	+ 1/ - 7,4	11,9	14,8	17,7				
1 800	1 875	+ 1/ - 8,2	13,3	16,6	19,9				
2 000	2 082	+ 1/ - 9,0	14,8	18,4	22,1				

NOTE 1 The bold figures indicate the standard products which are suitable for most applications. Grey boxes represent products which are outside the scope of this standard.

NOTE 2 For smaller DN, the minimum pipe wall thickness is governed by a combination of manufacturing constraints, structural performance and installation and handling requirements.

NOTE 3 The minimum thickness is given for non-restrained joints (see 4.2).

NOTE 4 Pressure classes between 50 and 100 may be supplied by interpolation on request.

8.2 Flanged pipes

The pressure class of the barrel of flanged pipes shall be equal to or greater than a value in bar equal to the PN of the flanges. The products shall comply with the test defined in 5.4. The thickness of integrally cast flanged pipes shall correspond to that of the fittings which are defined in 8.4 and 4.3.1.

8.3 Fittings for socketed joints

8.3.1 General

In the following tables, all the dimensions are nominal values and are given in millimetres. The values of L_u and l_u have been rounded off to the nearest multiple of five.

For coating and linings, see 4.6.

8.3.2

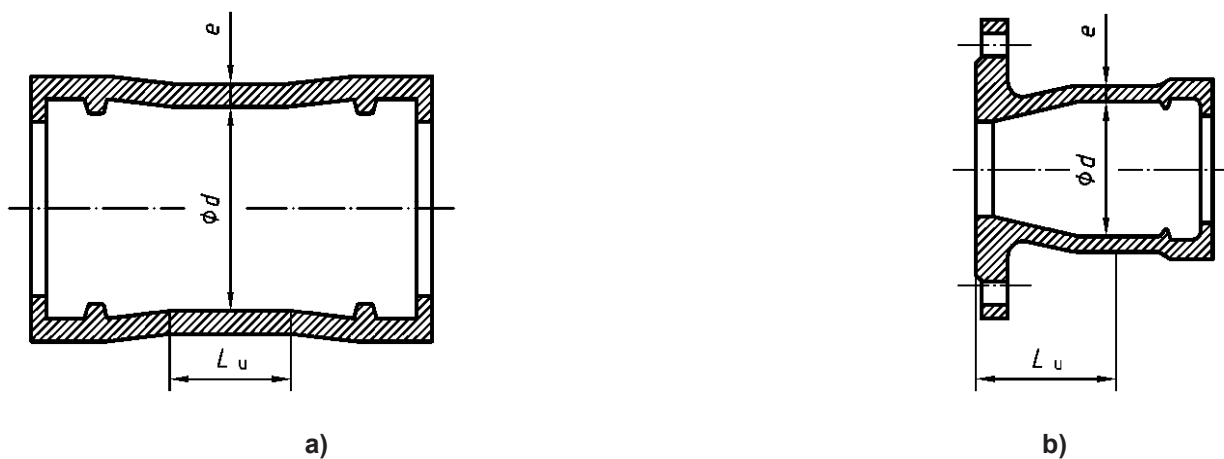

Figure 6 — Flanged sockets

Table 18 — Dimensions of flanged sockets

DN	<i>e</i>	<i>L_u</i> series A	<i>L_u</i> series B	<i>d</i>
40	7,0	125	75	67
50	7,0	125	85	78
60	7,0	125	100	88
65	7,0	125	105	93
80	7,0	130	105	109
100	7,2	130	110	130
125	7,5	135	115	156
150	7,8	135	120	183
200	8,4	140	120	235
250	9,0	145	125	288
300	9,6	150	130	340
350	10,2	155	135	393
400	10,8	160	140	445
450	11,4	165	145	498
500	12,0	170	-	550
600	13,2	180	-	655
700	14,4	190	-	760
800	15,6	200	-	865
900	16,8	210	-	970
1 000	18,0	220	-	1 075
1 100	19,2	230	-	1 180
1 200	20,4	240	-	1 285
1 400	22,8	310	-	1 477
1 500	24,0	330	-	1 580
1 600	25,2	330	-	1 683
1 800	27,6	350	-	1 889
2 000	30,0	370	-	2 095

8.3.3

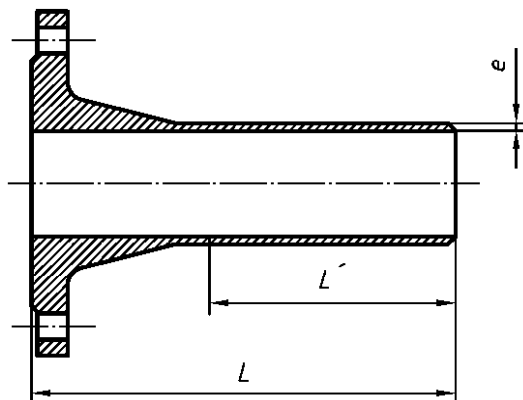

Figure 7 — Flanged spigots

8.3.4

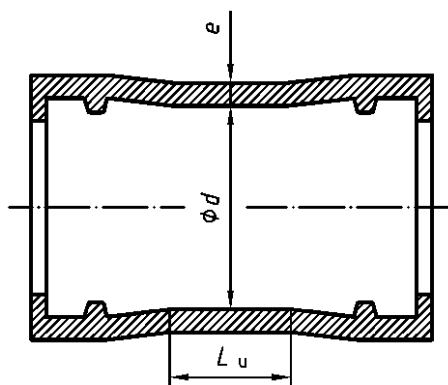

Figure 8 — Collars

Table 19 — Dimensions of flanged spigots and collars

DN	<i>e</i>	Flanged spigots			Collars		
		<i>L</i> series A	<i>L</i> series B	<i>L'</i>	<i>L_u</i> series A	<i>L_u</i> series B	<i>d</i>
40	7,0	335	335	200	155	155	67
50	7,0	340	340	200	155	155	78
60	7,0	345	345	200	155	155	88
65	7,0	345	345	200	155	155	93
80	7,0	350	350	215	160	160	109
100	7,2	360	360	215	160	160	130
125	7,5	370	370	220	165	165	156
150	7,8	380	380	225	165	165	183
200	8,4	400	400	230	170	170	235
250	9,0	420	420	240	175	175	288
300	9,6	440	440	250	180	180	340
350	10,2	460	460	260	185	185	393
400	10,8	480	480	270	190	190	445
450	11,4	500	500	280	195	195	498
500	12,0	520	-	290	200	-	550
600	13,2	560	-	310	210	-	655
700	14,4	600	-	330	220	-	760
800	15,6	600	-	330	230	-	865
900	16,8	600	-	330	240	-	970
1 000	18,0	600	-	330	250	-	1 075
1 100	19,2	600	-	330	260	-	1 180
1 200	20,4	600	-	330	270	-	1 285
1 400	22,8	710	-	390	340	-	1 477
1 500	24,0	750	-	410	350	-	1 580
1 600	25,2	780	-	430	360	-	1 683
1 800	27,6	850	-	470	380	-	1 889
2 000	30,0	920	-	500	400	-	2 095

NOTE The length *L'* is the length to which the value of DE and its limit deviations, as given in Tables 16 and 17, apply.

8.3.5

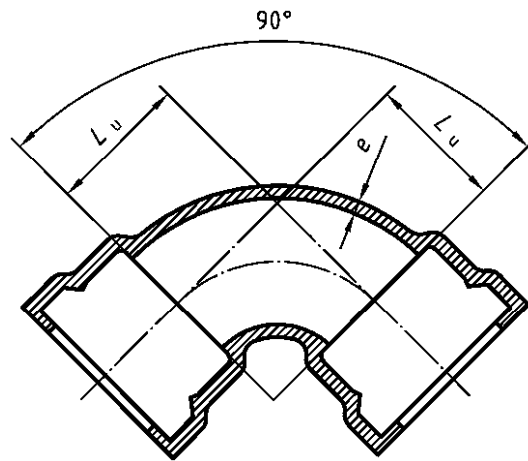

Figure 9 — Double socket 90° (1/4) bends

8.3.6

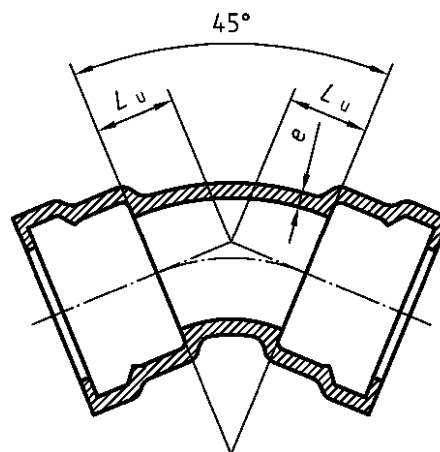

Figure 10 — Double socket 45° (1/8) bends

Table 20 — Dimensions of double socket 90° and 45° bends

DN	<i>e</i>	90° (1/4) bends		45° (1/8) bends	
		<i>L_u</i> series A	<i>L_u</i> series B	<i>L_u</i> series A	<i>L_u</i> series B
40	7,0	60	85	40	85
50	7,0	70	85	40	85
60	7,0	80	90	45	90
65	7,0	85	90	50	90
80	7,0	100	85	55	50
100	7,2	120	100	65	60
125	7,5	145	115	75	65
150	7,8	170	130	85	70
200	8,4	220	160	110	80
250	9,0	270	240	130	135
300	9,6	320	280	150	155
350	10,2	-	-	175	170
400	10,8	-	-	195	185
450	11,4	-	-	220	200
500	12,0	-	-	240	-
600	13,2	-	-	285	-
700	14,4	-	-	330	-
800	15,6	-	-	370	-
900	16,8	-	-	415	-
1 000	18,0	-	-	460	-
1 100	19,2	-	-	505	-
1 200	20,4	-	-	550	-
1 400	22,8	-	-	515	-
1 500	24,0	-	-	540	-
1 600	25,2	-	-	565	-
1 800	27,6	-	-	610	-
2 000	30,0	-	-	660	-

8.3.7

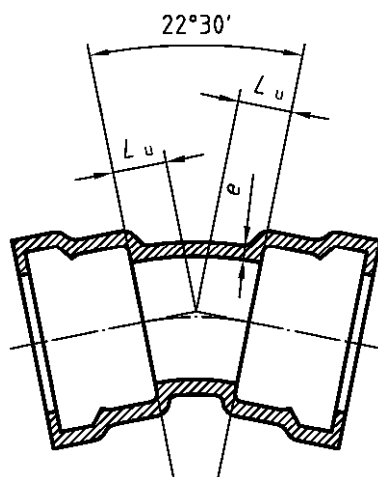

Figure 11 — Double socket 22°30' (1/16) bends

8.3.8

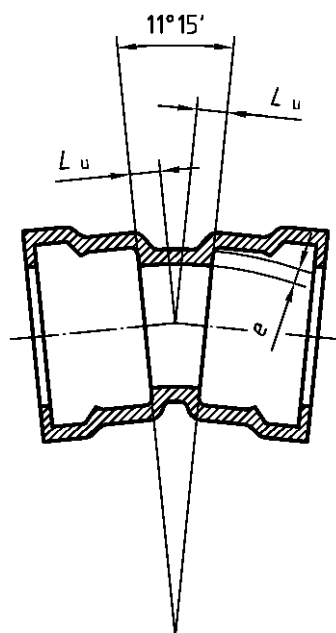

Figure 12 — Double socket 11°15' (1/32) bends

Table 21 — Dimensions of double socket 22,5° and 11,25° bends

DN	<i>e</i>	22°30' (1/16) bends		11°15' (1/32) bends	
		<i>L_u</i> series A	<i>L_u</i> series B	<i>L_u</i> series A	<i>L_u</i> series B
40	7,0	30	30	25	25
50	7,0	30	30	25	25
60	7,0	35	35	25	25
65	7,0	35	35	25	25
80	7,0	40	40	30	30
100	7,2	40	50	30	30
125	7,5	50	55	35	35
150	7,8	55	60	35	40
200	8,4	65	70	40	45
250	9,0	75	80	50	55
300	9,6	85	90	55	55
350	10,2	95	100	60	60
400	10,8	110	110	65	65
450	11,4	120	120	70	70
500	12,0	130	-	75	-
600	13,2	150	-	85	-
700	14,4	175	-	95	-
800	15,6	195	-	110	-
900	16,8	220	-	120	-
1 000	18,0	240	-	130	-
1 100	19,2	260	-	140	-
1 200	20,4	285	-	150	-
1 400	22,8	260	-	130	-
1 500	24,0	270	-	140	-
1 600	25,2	280	-	140	-
1 800	27,6	305	-	155	-
2 000	30,0	330	-	165	-

8.3.9

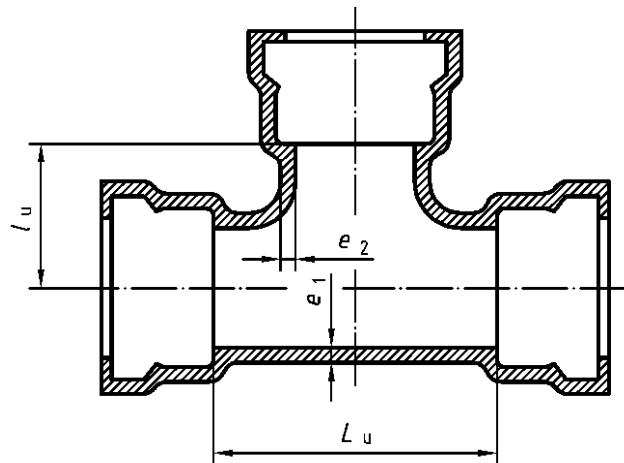

Figure 13 — All socket tees

Table 22 — Dimensions of all socket tees

DN × dn	Body			Branch		
	e_1	L_u series A	L_u series B	e_2	I_u series A	I_u series B
40 × 40	7,0	120	155	7,0	60	75
50 × 50	7,0	130	155	7,0	65	75
60 × 60	7,0	145	155	7,0	70	80
65 × 65	7,0	150	155	7,0	75	80
80 × 40	7,0	120	155	7,0	80	80
80 × 80	7,0	170	175	7,0	85	85
100 × 40	7,2	120	155	7,0	90	90
100 × 60	7,2	145	155	7,0	90	90
100 × 80	7,2	170	165	7,0	95	90
100 × 100	7,2	190	195	7,2	95	100
125 × 40	7,5	125	155	7,0	100	105
125 × 80	7,5	170	175	7,0	105	105
125 × 100	7,5	195	195	7,2	110	115
125 × 125	7,5	225	225	7,5	110	115
150 × 40	7,8	125	160	7,0	115	115
150 × 80	7,8	170	180	7,0	120	120
150 × 100	7,8	195	200	7,2	120	125
150 × 150	7,8	255	260	7,8	125	130
200 × 40	8,4	130	165	7,0	140	140
200 × 80	8,4	175	180	7,0	145	145
200 × 100	8,4	200	200	7,2	145	150
200 × 150	8,4	255	260	7,8	150	155
200 × 200	8,4	315	320	8,4	155	160
250 × 80	9,0	180	185	7,0	170	185
250 × 100	9,0	200	205	7,2	170	190
250 × 150	9,0	260	265	7,8	175	190
250 × 200	9,0	315	320	8,4	180	190
250 × 250	9,0	375	380	9,0	190	190
300 × 100	9,6	205	210	7,2	195	220
300 × 150	9,6	260	265	7,8	200	220
300 × 200	9,6	320	325	8,4	205	220
300 × 250	9,6	375	380	9,0	210	220
300 × 300	9,6	435	440	9,6	220	220

NOTE The main nominal size is designated DN and the nominal size of the branch is designated dn.

8.3.10

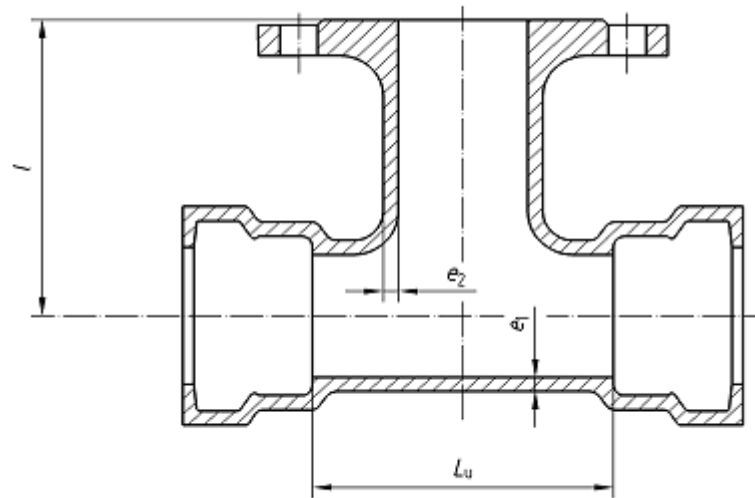

Figure 14 — Double socket tees with flanged branch

Table 23 — Dimensions of double socket tees with flanged branch, DN 40 to 250

DN × dn	Body			Branch		
	e ₁	L _u series A	L _u series B	e ₂	l series A	l series B
40 × 40	7,0	120	155	7,0	130	130
50 × 50	7,0	130	155	7,0	140	140
60 × 40	7,0	-	155	7,0	-	130
60 × 60	7,0	145	155	7,0	150	150
65 × 40	7,0	-	155	7,0	-	130
65 × 65	7,0	150	155	7,0	150	155
80 × 40	7,0	-	155	7,0	-	135
80 × 60	7,0	-	155	7,0	-	155
80 × 80	7,0	170	175	7,0	165	165
100 × 40	7,2	-	155	7,0	-	145
100 × 60	7,2	-	155	7,0	-	165
100 × 80	7,2	170	165	7,0	175	170
100 × 100	7,2	190	195	7,2	180	180
125 × 40	7,5	-	155	7,0	-	160
125 × 60	7,5	-	155	7,0	-	180
125 × 80	7,5	170	175	7,0	190	185
125 × 100	7,5	195	195	7,2	195	195
125 × 125	7,5	225	225	7,5	200	200
150 × 40	7,8	-	160	7,0	-	170
150 × 60	7,8	-	160	7,0	-	190
150 × 80	7,8	170	180	7,0	205	200
150 × 100	7,8	195	200	7,2	210	205
150 × 125	7,8	-	230	7,5	-	215
150 × 150	7,8	255	260	7,8	220	220
200 × 40	8,4	-	165	7,0	-	195
200 × 60	8,4	-	165	7,0	-	215
200 × 80	8,4	175	180	7,0	235	225
200 × 100	8,4	200	200	7,2	240	230
200 × 125	8,4	-	235	7,5	-	240
200 × 150	8,4	255	260	7,8	250	245
200 × 200	8,4	315	320	8,4	260	260
250 × 60	9,0	-	165	7,0	-	260
250 × 80	9,0	180	180	7,0	265	265
250 × 100	9,0	200	205	7,2	270	270
250 × 150	9,0	260	265	7,8	280	280
250 × 200	9,0	315	320	8,4	290	290
250 × 250	9,0	375	380	9,0	300	300

NOTE The main nominal size is designated DN and the nominal size of the branch is designated dn.

8.3.11 Double socket tees with flanged branch, DN 300 to DN 700

Table 24 — Dimensions of double socket tees with flanged branch, DN 300 to DN 700

DN × dn	Body			Branch		
	e_1	L_u series A	L_u series B	e_2	l series A	l series B
300 × 60	9,6	-	165	7,0	-	290
300 × 80	9,6	180	185	7,0	295	295
300 × 100	9,6	205	210	7,2	300	300
300 × 150	9,6	260	265	7,8	310	310
300 × 200	9,6	320	325	8,4	320	320
300 × 250	9,6	-	380	9,0	-	330
300 × 300	9,6	435	440	9,6	340	340
350 × 60	10,2	-	170	7,0	-	320
350 × 80	10,2	-	185	7,0	-	325
350 × 100	10,2	205	210	7,2	330	330
350 × 150	10,2	-	270	7,8	-	340
350 × 200	10,2	325	325	8,4	350	350
350 × 250	10,2	-	385	9,0	-	360
350 × 350	10,2	495	500	10,2	380	380
400 × 80	10,8	185	190	7,0	355	355
400 × 100	10,8	210	210	7,2	360	360
400 × 150	10,8	270	270	7,8	370	370
400 × 200	10,8	325	330	8,4	380	380
400 × 250	10,8	-	385	9,0	-	390
400 × 300	10,8	440	445	9,6	400	400
400 × 400	10,8	560	560	10,8	420	420
450 × 100	11,4	-	215	7,2	-	390
450 × 150	11,4	-	270	7,8	-	400
450 × 200	11,4	-	330	8,4	-	410
450 × 250	11,4	-	390	9,0	-	420
450 × 300	11,4	-	445	9,6	-	430
450 × 400	11,4	-	560	10,8	-	450
450 × 450	11,4	-	620	11,4	-	460
500 × 100	12,0	215	-	7,2	420	-
500 × 200	12,0	330	-	8,4	440	-
500 × 400	12,0	565	-	10,8	480	-
500 × 500	12,0	680	-	12,0	500	-
600 × 200	13,2	340	-	8,4	500	-
600 × 400	13,2	570	-	10,8	540	-
600 × 600	13,2	800	-	13,2	580	-
700 × 200	14,4	345	-	8,4	525	-
700 × 400	14,4	575	-	10,8	555	-
700 × 700	14,4	925	-	14,4	600	-

NOTE The main nominal size is designated DN and the nominal size of the branch is designated dn.

8.3.12 Double socket tees with flanged branch DN 800 to DN 2 000

Table 25 — Dimensions of double socket tees with flanged branch, DN 800 to DN 2 000

DN × dn	Body		Branch	
	e_1	L_u series A	e_2	l series A
800 × 200	15,6	350	8,4	585
800 × 400	15,6	580	10,8	615
800 × 600	15,6	1 045	13,2	645
800 × 800	15,6	1 045	15,8	675
900 × 200	16,8	355	8,4	645
900 × 400	16,8	590	10,8	675
900 × 600	16,8	1 170	13,2	705
900 × 900	16,8	1 170	16,8	750
1 000 × 200	18,0	360	8,4	705
1 000 × 400	18,0	595	10,8	735
1 000 × 600	18,0	1 290	13,2	765
1 000 × 1 000	18,0	1 290	18,0	825
1 100 × 400	19,2	600	10,8	795
1 100 × 600	19,2	830	13,2	825
1 200 × 600	20,4	840	13,2	885
1 200 × 800	20,4	1 070	15,6	915
1 200 × 1 000	20,4	1 300	18,0	945
1 400 × 600	22,8	1 030	13,2	980
1 400 × 800	22,8	1 260	15,6	1 010
1 400 × 1 000	22,8	1 495	18,0	1 040
1 500 × 600	24,0	1 035	13,2	1 035
1 500 × 1 000	24,0	1 500	18,0	1 595
1 600 × 600	25,2	1 040	13,2	1 090
1 600 × 800	25,2	1 275	15,6	1 120
1 600 × 1 000	25,2	1 505	18,0	1 150
1 600 × 1 200	25,2	1 740	20,4	1 180
1 800 × 600	27,6	1 055	13,2	1 200
1 800 × 800	27,6	1 285	15,6	1 230
1 800 × 1 000	27,6	1 520	18,0	1 260
1 800 × 1 200	27,6	1 750	20,4	1 290
2 000 × 600	30,0	1 065	13,2	1 310
2 000 × 1 000	30,0	1 530	18,0	1 370
2 000 × 1 400	30,0	1 995	22,8	1 430

NOTE The main nominal size is designated DN and the nominal size of the branch is designated dn.

8.3.13

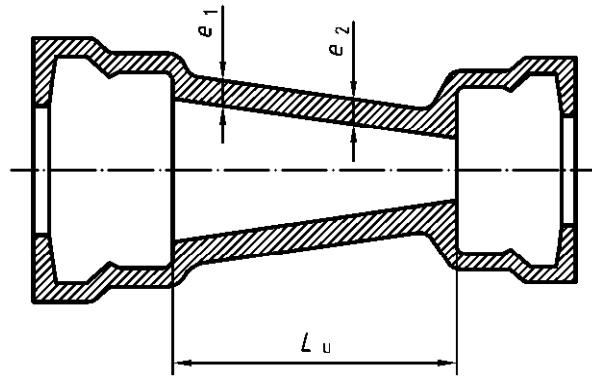

Figure 15 — Double socket tapers

Table 26 — Dimensions of double socket tapers

DN × dn	e_1	e_2	L_u series A	L_u series B
50 × 40	7,0	7,0	70	75
60 × 50	7,0	7,0	70	75
65 × 50	7,0	7,0	80	75
80 × 40	7,0	7,0	-	80
80 × 60	7,0	7,0	90	80
80 × 65	7,0	7,0	80	80
100 × 60	7,2	7,0	-	120
100 × 80	7,2	7,0	90	85
125 × 60	7,5	7,0	-	190
125 × 80	7,5	7,0	140	135
125 × 100	7,5	7,2	100	120
150 × 80	7,8	7,0	190	190
150 × 100	7,8	7,2	150	150
150 × 125	7,8	7,5	100	115
200 × 100	8,4	7,2	250	250
200 × 125	8,4	7,5	200	230
200 × 150	8,4	7,8	150	145
250 × 125	9,0	7,5	300	335
250 × 150	9,0	7,8	250	250
250 × 200	9,0	8,4	150	150
300 × 150	9,6	7,8	350	370
300 × 200	9,6	8,4	250	250
300 × 250	9,6	9,0	150	150
350 × 200	10,2	8,4	360	370
350 × 250	10,2	9,0	260	260
350 × 300	10,2	9,6	160	160
400 × 250	10,8	9,0	360	380
400 × 300	10,8	9,6	260	260
400 × 350	10,8	10,2	160	155
450 × 350	11,4	10,2	260	270
450 × 400	11,4	10,8	160	160
500 × 350	12,0	10,2	360	-
500 × 400	12,0	10,8	260	-
600 × 400	13,2	10,8	460	-
<i>(to be continued)</i>				

Table 26 (continued)

DN × dn	e_1	e_2	L_u series A	L_u series B
600 × 500	13,2	12,0	260	-
700 × 500	14,4	12,0	480	-
700 × 600	14,4	13,2	280	-
800 × 600	15,6	13,2	480	-
800 × 700	15,6	14,4	280	-
900 × 700	16,8	14,4	480	-
900 × 800	16,8	15,6	280	-
1 000 × 800	18,0	15,6	480	-
1 000 × 900	18,0	16,8	280	-
1 100 × 1 000	19,2	18,0	280	-
1 200 × 1 000	20,4	18,0	480	-
1 400 × 1 200	22,8	20,4	360	-
1 500 × 1 400	24,0	22,8	260	-
1 600 × 1 400	25,2	22,8	360	-
1 800 × 1 600	27,6	25,2	360	-
2 000 × 1 800	30,0	27,6	360	-

NOTE The larger end is designated DN and the smaller end is designated dn.

8.4 Fittings for flanged joints

8.4.1 General

In the following tables, all the dimensions are nominal values and are given in millimetres. For coatings and linings, see 4.6.

8.4.2

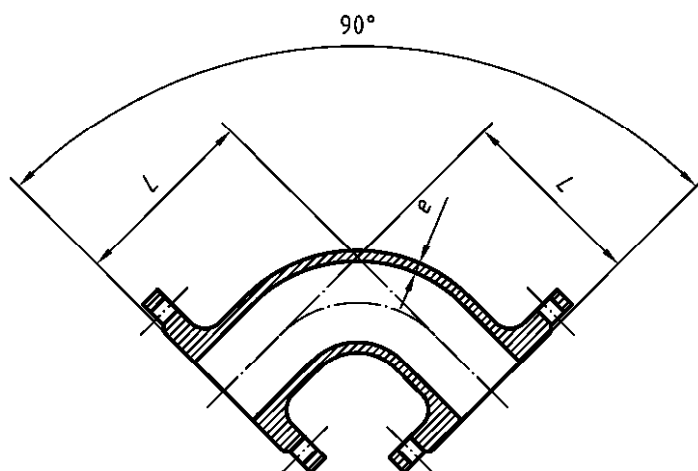

Figure 16 — Double flanged 90° (1/4) bends

8.4.3

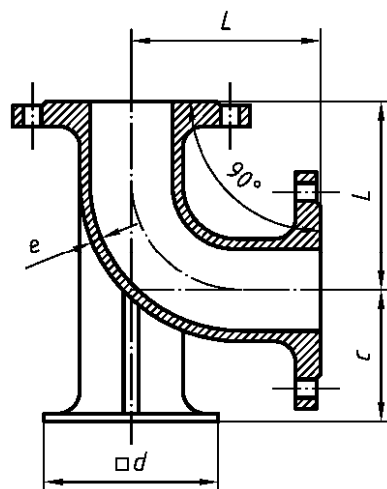

Figure 17 — Double flanged duckfoot 90° (1/4) bends

Table 27 — Dimensions of double flanged 90° and 90° duckfoot bends

DN	A and B series				
	<i>e</i>	90° (1/4) bends	90° (1/4) duckfoot bends		
		<i>L</i>	<i>L</i>	<i>c</i>	<i>d</i>
40	7,0	140	-	-	-
50	7,0	150	150	95	150
60	7,0	160	160	100	160
65	7,0	165	165	100	165
80	7,0	165	165	110	180
100	7,2	180	180	125	200
125	7,5	200	200	140	225
150	7,8	220	220	160	250
200	8,4	260	260	190	300
250	9,0	350	350	225	350
300	9,6	400	400	255	400
350	10,2	450	450	290	450
400	10,8	500	500	320	500
450	11,4	550	550	355	550
500	12,0	600	600	385	600
600	13,2	700	700	450	700
700	14,4	800	-	-	-
800	15,6	900	-	-	-
900	16,8	1 000	-	-	-
1 000	18,0	1 100	-	-	-

8.4.4

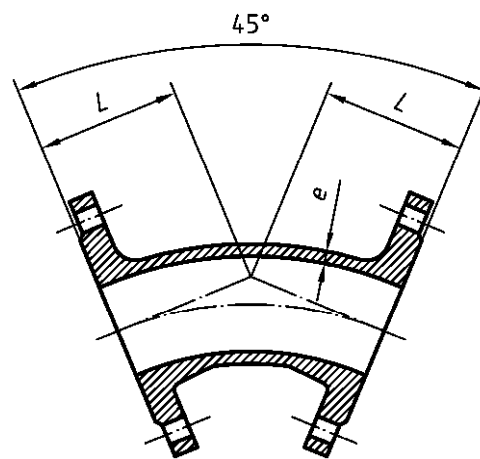

Figure 18 — Double flanged 45° (1/8) bends

Table 28 — Dimensions of double flanged 45° bends

DN	<i>e</i>	<i>L</i> series A	<i>L</i> series B
40	7,0	140	140
50	7,0	150	150
60	7,0	160	160
65	7,0	165	165
80	7,0	130	130
100	7,2	140	140
125	7,5	150	150
150	7,8	160	160
200	8,4	180	180
250	9,0	350	245
300	9,6	400	275
350	10,2	298	300
400	10,8	324	325
450	11,4	350	350
500	12,0	375	-
600	13,2	426	-
700	14,4	478	-
800	15,6	529	-
900	16,8	581	-
1 000	18,0	632	-
1 100	18,2	694	-
1 200	20,4	750	-
1 400	22,8	775	-
1 500	24,0	810	-
1 600	25,2	845	-
1 800	27,6	910	-
2 000	30,0	980	-

8.4.5

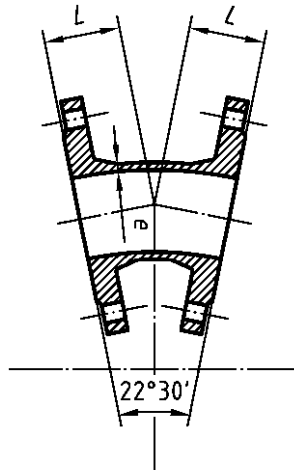

Figure 19 — Double flanged 22°30' (1/16) bends

8.4.6

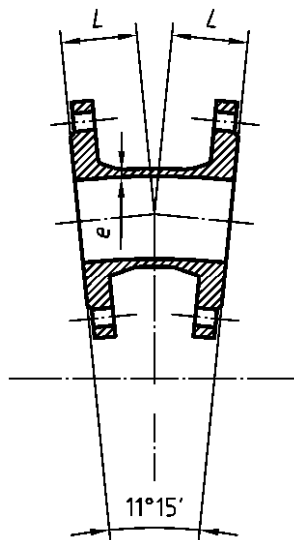

Figure 20 — Double flanged 11°15' (1/32) bends

Table 29 — Dimensions of double flanged 22,5° and 11,25° bends

DN	22°30' (1/16) bends			11°15' (1/32) bends		
	<i>e</i>	<i>L</i> series A	<i>L</i> series B	<i>e</i>	<i>L</i> series A	<i>L</i> series B
40	7,0	94	85	7,0	99	80
50	7,0	104	95	7,0	109	90
60	7,0	114	105	7,0	119	100
65	7,0	119	110	7,0	124	105
80	7,0	105	120	7,0	113	110
100	7,2	110	130	7,2	115	115
125	7,5	105	140	7,5	111	120
150	7,8	109	150	7,8	113	130
200	8,4	131	170	8,4	132	145
250	9,0	190	190	9,0	165	165
300	9,6	210	210	9,6	175	175
350	10,2	210	230	10,2	191	190
400	10,8	239	250	10,8	205	205

NOTE Double-flanged 22°30' and 11°15' bends of sizes larger than DN 400 are available, but with a range of effective lengths, depending on the manufacturer.

8.4.7

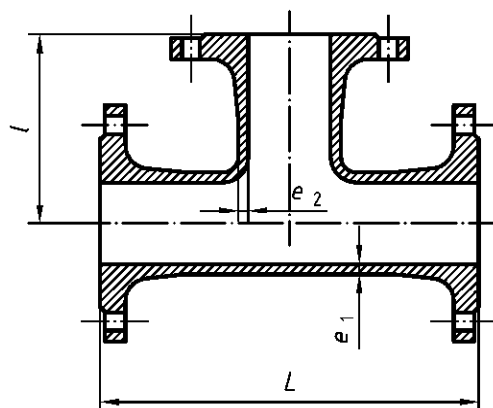

Figure 21 — All flanged tees

Table 30 — Dimensions of all flanged tees, DN 40 to DN 250

DN × dn	Body			Branch		
	e_1	L series A	L series B	e_2	I series A	I series B
40 × 40	7,0	280	255	7,0	140	130
50 × 50	7,0	300	280	7,0	150	140
60 × 40	7,0	300	-	7,0	130	-
60 × 60	7,0	320	300	7,0	160	150
65 × 65	7,0	330	305	7,0	165	150
80 × 40	7,0	-	310	7,0	-	135
80 × 60	7,0	-	310	7,0	-	155
80 × 80	7,0	330	330	7,0	165	165
100 × 40	7,2	-	320	7,0		145
100 × 60	7,2	-	320	7,0		165
100 × 80	7,2	360	330	7,0	175	170
100 × 100	7,2	360	360	7,2	180	180
125 × 40	7,5	-	330	7,0	-	160
125 × 60	7,5	-	330	7,0	-	180
125 × 80	7,5	400	350	7,0	190	185
125 × 100	7,5	400	370	7,2	195	195
125 × 125	7,5	400	400	7,5	200	200
150 × 40	7,8	-	340	7,0	-	170
150 × 60	7,8	-	340	7,0	-	190
150 × 80	7,8	440	360	7,0	205	200
150 × 100	7,8	440	380	7,2	210	205
150 × 125	7,8	440	410	7,5	215	215
150 × 150	7,8	440	440	7,8	220	220
200 × 40	8,4	-	365	7,0	-	195
200 × 60	8,4	-	365	7,0	-	215
200 × 80	8,4	520	380	7,0	235	225
200 × 100	8,4	520	400	7,2	240	230
200 × 125	8,4	-	435	7,5	-	240
200 × 150	8,4	520	460	7,8	250	245
200 × 200	8,4	520	520	8,4	260	260
250 × 60	9,0	-	385	7,0	-	260
250 × 80	9,0	-	405	7,0	-	265
250 × 100	9,0	700	425	7,2	275	270
250 × 150	9,0	-	485	7,8	-	280
250 × 200	9,0	700	540	8,4	325	290
250 × 250	9,0	700	600	9,0	350	300

NOTE The main nominal size is designated DN and the nominal size of the branch is designated dn.

8.4.8 All flanged tees, DN 300 to DN 700

Table 31 — Dimensions of all flanged tees, DN 300 to DN 700

DN × dn	Body			Branch		
	e_1	L series A	L series B	e_2	/ series A	/ series B
300 × 60	9,6	-	405	7,0	-	290
300 × 80	9,6	-	425	7,0	-	295
300 × 100	9,6	800	450	7,2	300	300
300 × 150	9,6	-	505	7,8	-	310
300 × 200	9,6	800	565	8,4	350	320
300 × 250	9,6	-	620	9,0	-	330
300 × 300	9,6	800	680	9,6	400	340
350 × 60	10,2	-	430	7,0	-	320
350 × 80	10,2	-	445	7,0	-	325
350 × 100	10,2	850	470	7,2	325	330
350 × 150	10,2	-	530	7,8	-	340
350 × 200	10,2	850	585	8,4	325	350
350 × 250	10,2	-	645	9,0	-	360
350 × 350	10,2	850	760	10,2	425	380
400 × 80	10,8	-	470	7,0	-	355
400 × 100	10,8	900	490	7,2	350	360
400 × 150	10,8	-	550	7,8	-	370
400 × 200	10,8	900	610	8,4	350	380
400 × 250	10,8	-	665	9,0	-	390
400 × 300	10,8	-	725	9,6	-	400
400 × 400	10,8	900	840	10,8	450	420
450 × 100	11,4	950	515	7,2	375	390
450 × 150	11,4	-	570	7,8	-	400
450 × 200	11,4	950	630	8,4	375	410
450 × 250	11,4	-	690	9,0	-	420
450 × 300	11,4	-	745	9,6	-	430
450 × 400	11,4	-	860	10,8	-	450
450 × 450	11,4	950	920	11,4	475	460
500 × 100	12,0	1 000	535	7,4	400	420
500 × 200	12,0	1 000	650	8,4	400	440
500 × 400	12,0	1 000	885	10,8	500	480
500 × 500	12,0	1 000	1 000	12,0	500	500
600 × 200	13,2	1 100	700	8,4	450	500
600 × 400	13,2	1 100	930	10,8	550	540
600 × 600	13,2	1 100	1 165	13,2	550	580
700 × 200	14,4	650	-	8,4	525	-
700 × 400	14,4	870	-	10,8	555	-
700 × 700	14,4	1 200	-	14,4	600	-

NOTE The main nominal size is designated DN and the nominal size of the branch is designated dn.

8.4.9 All flanged tees, DN 800 to DN 2000

Table 32 — Dimensions of all flanged tees, DN 800 to DN 2000

DN × dn	Body		Branch	
	<i>e</i> ₁	<i>L</i> series A	<i>e</i> ₂	<i>l</i> series A
800 × 200	15,6	690	8,4	585
800 × 400	15,6	910	10,8	615
800 × 600	15,6	1 350	13,2	645
800 × 800	15,6	1 350	15,6	675
900 × 200	16,8	730	8,4	645
900 × 400	16,8	950	10,8	675
900 × 600	16,8	1 500	13,2	705
900 × 900	16,8	1 500	16,8	750
1 000 × 200	18,0	770	8,4	705
1 000 × 400	18,0	990	10,8	735
1 000 × 600	18,0	1 650	13,2	765
1 000 × 1 000	18,0	1 650	18,0	825
1 100 × 400	19,2	980	8,4	795
1 100 × 600	19,2	1 210	13,2	825
1 200 × 600	20,4	1 240	13,2	885
1 200 × 800	20,4	1 470	15,6	915
1 200 × 1000	20,4	1 700	18,0	945
1 400 × 600	22,8	1 550	13,2	980
1 400 × 800	22,8	1 760	15,6	1 010
1 400 × 1000	22,8	2 015	18,0	1 040
1 500 × 600	24,0	1 575	13,2	1 035
1 500 × 1000	24,0	2 040	18,0	1 095
1 600 × 600	25,2	1 600	13,2	1 090
1 600 × 800	25,2	1 835	15,6	1 120
1 600 × 1000	25,2	2 065	18,0	1 150
1 600 × 1200	25,2	2 300	20,4	1 180
1 800 × 600	27,6	1 655	13,2	1 200
1 800 × 800	27,6	1 885	15,6	1 230
1 800 × 1000	27,6	2 120	18,0	1 260
1 800 × 1200	27,6	2 350	20,4	1 290
2 000 × 600	30,0	1 705	13,2	1 310
2 000 × 1 000	30,0	2 170	18,0	1 370
2 000 × 1 400	30,0	2 635	22,8	1 430

NOTE The main nominal size is designated DN and the nominal size of the branch is designated dn

8.4.10

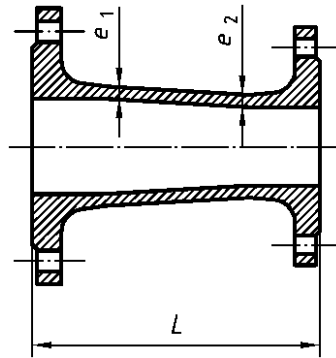

Figure 22 — Double flanged tapers

Table 33 — Dimensions of double flanged tapers

DN × dn	<i>e</i> ₁	<i>e</i> ₂	L series A	L series B
50 × 40	7,0	7,0	150	165
60 × 50	7,0	7,0	160	160
65 × 50	7,0	7,0	200	190
80 × 60	7,0	7,0	200	185
80 × 65	7,0	7,0	200	190
100 × 80	7,2	7,0	200	195
125 × 100	7,5	7,2	200	185
150 × 125	7,8	7,5	200	190
200 × 150	8,4	7,8	300	235
250 × 200	9,0	8,4	300	250
300 × 250	9,6	9,0	300	265
350 × 300	10,2	9,6	300	290
400 × 300	10,8	9,6	300	-
400 × 350	10,8	10,2	300	305
450 × 400	11,4	10,8	300	320
500 × 400	12,0	10,8	600	-
600 × 500	13,2	12,0	600	-
700 × 600	14,4	13,2	600	-
800 × 700	15,6	14,4	600	-
900 × 800	16,8	15,6	600	-
1 000 × 900	18,0	16,8	600	-
1 100 × 1 000	19,2	18,0	600	-
1 200 × 1 000	20,4	18,0	790	-
1 400 × 1 200	22,8	20,4	850	-
1 500 × 1 400	24,0	22,8	695	-
1 600 × 1 400	25,2	22,8	910	-
1 800 × 1 600	27,6	25,2	970	-
2 000 × 1 800	30,0	27,6	1 030	-

NOTE The larger end is designated DN and the smaller end is designated dn.

8.4.11

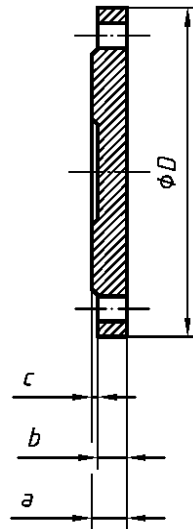

Figure 23 — Blank flanges PN 10

8.4.12

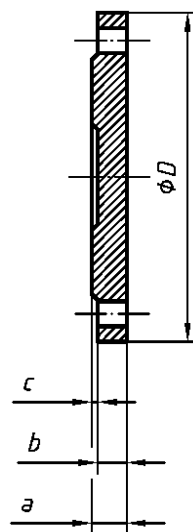

Figure 24 — Blank flanges PN 16

Table 34 — Dimensions of PN 10 and PN 16 blank flanges

DN	PN 10				PN 16			
	<i>D</i>	<i>a</i>	<i>b</i>	<i>c</i>	<i>D</i>	<i>a</i>	<i>b</i>	<i>c</i>
40	150	19	16	3	150	19	16	3
50	165	19	16	3	165	19	16	3
60	175	19	16	3	175	19	16	3
65	185	19	16	3	185	19	16	3
80	200	19	16	3	200	19	16	3
100	220	19	16	3	220	19	16	3
125	250	19	16	3	250	19	16	3
150	285	19	16	3	285	19	16	3
200	340	20	17	3	340	20	17	3
250	400	22	19	3	400	22	19	3
300	455	24,5	20,5	4	455	24,5	20,5	4
350	505	24,5	20,5	4	520	26,5	22,5	4
400	565	24,5	20,5	4	580	28	24	4
450	615	25,5	21,5	4	640	30	26	4
500	670	26,5	22,5	4	715	31,5	27,5	4
600	780	30	25	5	840	36	31	5
700	895	32,5	27,5	5	910	39,5	34,5	5
800	1 015	35	30	5	1 025	43	38	5
900	1 115	37,5	32,5	5	1 125	46,5	41,5	5
1 000	1 230	40	35	5	1 255	50	45	5
1 100	1 340	42,5	37,5	5	1 355	53,5	48,5	5
1 200	1455	45	40	5	1 485	57	52	5
1 400	1 675	46	41	5	1 685	60	55	5
1 500	1 785	47,5	42,5	5	1 820	62,5	57,5	5
1 600	1 915	49	44	5	1 930	65	60	5
1 800	2 115	52	47	5	2 130	70	65	5
2 000	2 325	55	50	5	2 345	75	70	5

NOTE For blank flanges of nominal diameter greater than or equal to DN 300, the centre of blank flanges may be dished.

8.4.13

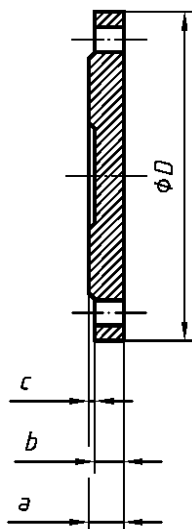

Figure 25 — Blank flanges PN 25

8.4.14

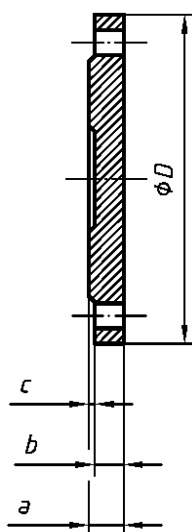

Figure 26 — Blank flanges PN 40

Table 35 — Dimensions of PN 25 and PN 40 blank flanges

DN	PN 25				PN 40			
	<i>D</i>	<i>a</i>	<i>b</i>	<i>c</i>	<i>D</i>	<i>a</i>	<i>b</i>	<i>c</i>
40	150	19	16	3	150	19	16	3
50	165	19	16	3	165	19	16	3
60	175	19	16	3	175	19	16	3
65	185	19	16	3	185	19	16	3
80	200	19	16	3	200	19	16	3
100	235	19	16	3	235	19	16	3
125	270	19	16	3	270	23,5	20,5	3
150	300	20	17	3	300	26	23	3
200	360	22	19	3	375	30	27	3
250	425	24,5	21,5	3	450	34,5	31,5	3
300	485	27,5	23,5	4	515	39,5	35,5	4
350	555	30	26	4	-	-	-	-
400	620	32	28	4	-	-	-	-
450	670	34,5	30,5	4	-	-	-	-
500	730	36,5	32,5	4	-	-	-	-
600	845	42	37	5	-	-	-	-

NOTE For blank flanges of nominal diameter greater than or equal to DN 300, the centre of blank flanges may be dished.

8.4.15

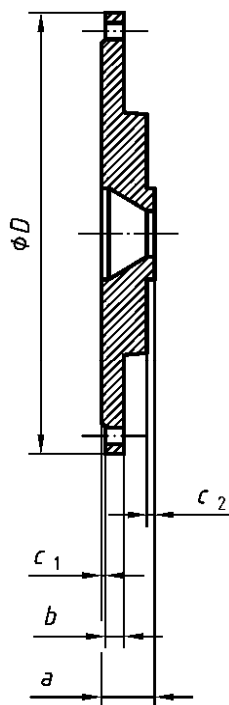

Figure 27 — Reducing flanges PN 10

8.4.16

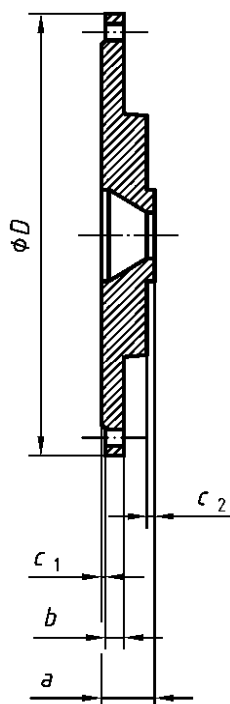

Figure 28 — Reducing flanges PN 16

Table 36 — Dimensions of PN 10 and PN 16 reducing flanges

DN × dn	PN 10					PN 16				
	<i>D</i>	<i>a</i>	<i>b</i>	<i>c</i> ₁	<i>c</i> ₂	<i>D</i>	<i>a</i>	<i>b</i>	<i>c</i> ₁	<i>c</i> ₂
200 × 80	340	40	17	3	3	340	40	17	3	3
200 × 100	340	40	17	3	3	340	40	17	3	3
200 × 125	340	40	17	3	3	340	40	17	3	3
350 × 250	505	48	20,5	4	3	520	54	22,5	4	3
400 × 250	565	48	20,5	4	3	580	54	24	4	3
400 × 300	565	49	20,5	4	4	580	55	24	4	4
700 × 500	895	56	27,5	5	4	910	67	34,5	5	4
900 × 700	1 115	63	32,5	5	5	1 125	73	41,5	5	5
1 000 × 700	1 230	63	35	5	5	1 255	73	45	5	5
1 000 × 800	1 230	68	35	5	5	1 255	77	45	5	5

NOTE The main nominal size is designated DN and the smaller nominal size is designated dn.

8.4.17

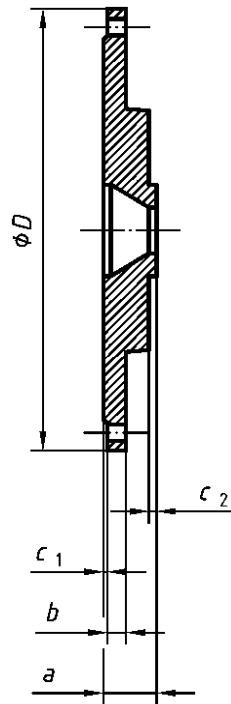

Figure 29 — Reducing flanges PN 25

8.4.18

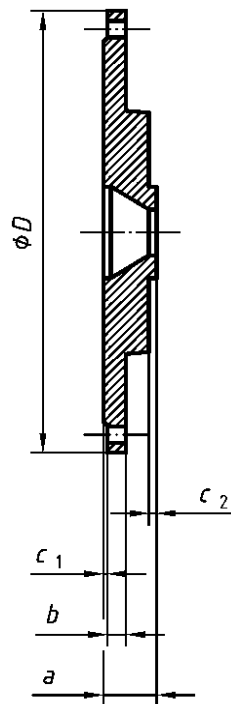

Figure 30 — Reducing flanges PN 40

Table 37 — Dimensions of PN 25 and PN 40 reducing flanges

DN × dn	PN 25					PN 40				
	<i>D</i>	<i>a</i>	<i>b</i>	<i>c</i> ₁	<i>c</i> ₂	<i>D</i>	<i>a</i>	<i>b</i>	<i>c</i> ₁	<i>c</i> ₂
200 × 80	360	40	19	3	3	375	40	27	3	3
200 × 100	360	47	19	3	3	375	47	27	3	3
200 × 125	360	53	19	3	3	375	53	27	3	3
350 × 250	555	60	26	4	3	-	-	-	-	-
400 × 250	620	60	28	4	3	-	-	-	-	-
400 × 300	620	61	28	4	4	-	-	-	-	-

NOTE The main nominal size is designated DN and the smaller nominal size is designated dn.

9 Evaluation of conformity

9.1 General

The conformity of ductile iron pipes, fittings, accessories and their joints with the requirements of this standard and with the declared values (including classes) shall be demonstrated by:

- initial performance testing;
- factory production control by the manufacturer, including product assessment.

For the purposes of testing, the products may be grouped into families (see 5.1), where it is considered that the results for one or more characteristics from any product within the family are representative for the same characteristics for all products within that family.

9.2 Initial performance testing

9.2.1 General

Initial performance testing shall be performed to show conformity with this European standard. Tests previously performed in accordance with the provisions of this European standard (same product, same characteristic(s), test method, sampling procedure, system of attestation of conformity, etc.) may be taken into account. In addition, initial performance testing shall be performed at the beginning of the production of a new type of product or at the beginning of a new method of production (where this may affect the stated properties).

For components, whose characteristics have already been determined by the component manufacturer, are used on the basis of conformity with other product standards, these characteristics do not need to be reassessed, provided that the components' performance or method of assessment remain the same, that the characteristics of the component are suitable for the intended end use of the finished product, and insofar as the manufacturing process does not have a detrimental affect on the determined characteristics.

Components and raw materials CE marked in accordance with appropriate harmonised European specifications may be presumed to have the performances stated with the CE marking. However this does not replace the responsibility on the manufacturer of ductile iron pipeline product to ensure that the product as a whole is correctly designed and its component products have the necessary performance values to meet the design.

9.2.2 Characteristics

All characteristics in Clause 5 shall be subject to initial performance testing except for the release of dangerous substances that may be assessed indirectly by controlling the content of the substance concerned.

Whenever a change occurs in the product, the raw material or supplier of the components, or the production process (subject to the definition of a family), which would change significantly one or more of the characteristics, the performance tests shall be repeated for the appropriate characteristics.

9.2.3 Treatment of calculated values and design

In those cases where conformity with this standard is based on calculations, performance testing will be limited to the verification of the calculations made and that the resulting products correspond to the assumptions made in the design.

9.2.4 Sampling, testing and conformity criteria

9.2.4.1 Sampling procedure

Initial performance testing shall be performed on samples of products representative for the manufactured product type.

The random sampling method shall be used, except for the assessment of the leak tightness of joints which requires samples at the extreme of tolerances (see 5.2, 5.3 and 5.5).

9.2.4.2 Testing and compliance criteria

The number of test samples to be tested (or assessed) shall be in accordance with Table 38.

The results of all performance tests shall be recorded and held by the manufacturer for at least 10 years after the last date of production of the product(s) to which they apply.

Table 38 — Number of test samples for initial performance testing

Items to be tested	Number of samples (minimum)				Test method in accordance with:	Requirements in accordance with:
Internal pressure strength	1 per DN				Calculation Annex A.2	4.2
Leak tightness of flexible joints:	1 of each DN grouping				7.2	5.2 or 5.3
— To positive internal pressure	DN 80	DN 300	DN 700	DN 1 100	7.2.2	5.2.2
— To negative internal pressure					7.2.3	5.2.2
— To positive external pressure	to	to	to	to	7.2.4	5.2.2
— To dynamic internal pressure	DN 250	DN 600	DN 1 000	DN 2 000	7.2.5	5.2.2
Strength and leak tightness of flanged joints	1 of each DN grouping					
	DN 80 to DN 250	DN 300 to DN 600	DN 700 to DN 1 000	DN 1 100 to DN 2 000	7.3	5.4
Leak tightness of pipe saddles:	1 of each DN grouping					
— To positive internal pressure	DN 80 to DN 250		DN 300 to DN 600		7.4.1	5.5.1
— To negative internal pressure					7.4.2	5.5.1
Compressive strength of the cement mortar lining	Mean of 6 tests on 3 samples				7.1	4.5.3.2

9.3 Factory production control (FPC)

9.3.1 General

The manufacturer shall establish, document and maintain an FPC system to ensure that the products placed on the market conform to the declared performance characteristics and to all requirements of this standard. The FPC system shall consist of procedures (works' manual), regular inspections and tests and/or assessments and the use of the results to control raw and other incoming materials or components, equipment, the production process and the product. Records shall remain legible, readily identifiable and retrievable.

The FPC system may be part of a Quality Management System, e.g. in accordance with EN ISO 9001:2000.

An FPC system conforming with the requirements of EN ISO 9001:2000, and made specific to the requirements of this standard, shall be considered to satisfy the above requirements.

The results of inspections, tests or assessments requiring action shall be recorded, as shall any action taken. The action to be taken when control values or criteria are not met shall be recorded and retained for the period specified in the manufacturer's FPC procedures.

If the manufacturer has the component designed, manufactured, assembled, packed, processed and/or labelled by subcontracting, FPC of the original manufacturer may be taken into account. However, where subcontracting takes place, the manufacturer shall retain the overall control of the component and ensure that he receives all the information that is necessary to fulfil his responsibilities according to this European Standard.

9.3.2 FPC requirements for all manufacturers

9.3.2.1 General

The manufacturer shall establish procedures to ensure that the production tolerances allow for the products performances to be in conformity with the declared values, derived from initial performance testing.

The characteristics, and the means of verification, are given in Table 39. The minimum testing frequencies apply to permanent production in large quantities with a stable process. The actual testing frequencies to be used in order to ensure permanent conformity of the products shall be fixed by the manufacturer's FPC, taking into account the production rate and the process control measures which are implemented.

The manufacturer shall record the results of the tests specified above. These records shall at least include the following information:

- identification of the product tested;
- date of sampling and testing;
- test methods performed;
- test results.

Table 39 — Minimum frequency of product testing as part of FPC

Items to be tested	Test method in accordance with:	Requirements in accordance with:	Minimum frequency of test
Dimensions:			
— Wall thickness	6.1.1	4.3.1	1 per shift
— External diameter of spigots	6.1.2	4.3.2.1	10 %
— Internal diameter	6.1.3	4.3.2.2	1 per shift
— Length of pipes	6.1.4	4.3.3	1 per week
— Straightness of pipes	6.2	4.3.4	1 %
Material characteristics:			
— Tensile testing	6.3	4.4.1	see 9.3.2.2
— Brinell hardness	6.4	4.4.2	1 per week
Coatings and linings of pipes:			
— Zinc coating mass	6.6	4.5.2.2	1 per shift
— Thickness of paint coatings	6.7	4.5.2.2	1 per shift
— Thickness of cement mortar lining	6.8	4.5.3.3	1 per shift
Coatings of fittings and accessories:			
— Epoxy coating	EN 14901	4.6.1	1 per shift
— Paint coating	6.7	4.6.2.2	1 per shift
Leak tightness for pipes and fittings:			
— Works leak tightness test	6.5	4.8	100 %

9.3.2.2 FPC for tensile testing

During the manufacturing process the manufacturer shall carry out suitable tests in order to verify the tensile properties specified in 4.4.1. These tests may be:

- a) A batch¹⁾ sampling system whereby samples are obtained from the pipe spigot or, for fittings, from samples cast separately or attached with the castings concerned: test bars are machined from these samples and tensile tested in accordance with 6.3; or
- b) A system of process control (e.g. by non-destructive testing) where a positive correlation can be demonstrated with the tensile properties specified in Table 8: testing verification procedures are based on the use of comparator samples having known and verifiable properties. This system is supported by tensile testing in accordance with 6.3.

The frequency of testing is related to the system of production and quality control used by the manufacturer. The maximum batch sizes shall be as given in Table 40.

1) Batch is the quantity of castings from which a sample is taken for testing purposes during manufacture.

Table 40 — Maximum batch sizes for tensile testing

Type of casting	DN	Maximum batch size	
		Batch sampling system	Process control system
Centrifugally cast pipes	40 to 300	200 pipes	1 200 pipes
	350 to 600	100 pipes	600 pipes
	700 to 1 000	50 pipes	300 pipes
	1 100 to 2 000	25 pipes	150 pipes
Pipes not centrifugally cast, fittings and accessories	40 to 2 000	4t ^a	48t ^a
^a Weight of crude castings, excluding the risers.			

9.3.3 Manufacturer-specific FPC system requirements

9.3.3.1 Personnel

The responsibility, authority and the relationship between personnel that manages, performs or verifies work affecting product conformity, shall be defined. This applies in particular to personnel that need to initiate actions preventing product non-conformities from occurring, actions in case of non-conformities and to identify and register product conformity problems. Personnel performing work affecting product conformity shall be competent on the basis of appropriate education, training, skills and experience for which records shall be maintained.

9.3.3.2 Equipment

All weighing, measuring and testing equipment necessary to achieve, or produce evidence of, conformity shall be calibrated or verified, and regularly inspected according to documented procedures, frequencies and criteria. Control of monitoring and measuring devices shall comply with the appropriate clause of EN ISO 9001:2000.

All equipment used in the manufacturing process shall be regularly inspected and maintained to ensure use, wear or failure does not cause inconsistency in the manufacturing process.

Inspections and maintenance shall be carried out and recorded in accordance with the manufacturer's written procedures and the records retained for the period defined in the manufacturer's FPC procedures.

9.3.3.3 Design process

The factory production control system shall document the various stages in the design of the products, identify the checking procedure and those individuals responsible for all stages of design.

During the design process itself, a record shall be kept of all checks, their results, and any corrective actions taken. This record shall be sufficiently detailed and accurate to demonstrate that all stages of the design phase, and all checks, have been carried out satisfactorily. Compliance with EN ISO 9001:2000, 7.3, shall be deemed to satisfy the requirements of this subclause.

9.3.3.4 Raw materials and components

The specifications of all incoming raw materials and components shall be documented, as shall the inspection scheme for ensuring their conformity. The verification of conformity of the raw materials with the specification shall be in accordance with EN ISO 9001:2000, 7.4.3.

9.3.3.5 In-process control

The manufacturer shall plan and carry out production under controlled conditions. Compliance with EN ISO 9001:2000, 7.5.1 and 7.5.2, shall be deemed to satisfy the requirements of this subclause.

9.3.3.6 Non-conforming products

The manufacturer shall have written procedures which specify how non-conforming products shall be dealt with. Any such events shall be recorded as they occur and these records shall be kept for the period defined in the manufacturer's written procedures. Compliance with EN ISO 9001:2000, 8.3, shall be deemed to satisfy the requirements of this subclause.

9.3.3.7 Corrective action

The manufacturer shall have documented procedures that instigate action to eliminate the cause of non-conformities in order to prevent recurrence. Compliance with EN ISO 9001:2000, 8.5.2, shall be deemed to satisfy the requirements of this sub-clause.

Annex A (normative)

Allowable pressures

A.1 General

The maximum values of PFA, PMA and PEA for components, as defined in 3.20, 3.22 and 3.23 respectively, shall be as given (in bars) in A.2, A.3 and A.4.

Appropriate limitations shall be taken into account, which may prevent the full range of these pressures being used in an installed pipeline, for example:

- operation at the PFA and PMA values given in A.2 for socket and spigot pipes may be limited by the lower pressure capability of other pipeline components, e.g. flanged pipework (see A.4), certain types of tees (see A.3) and specific designs of flexible and restrained flexible joints (see 5.2. and 5.3);
- site hydrostatic testing at the high PEA values given in A.2 may be limited by the type and design of the pipeline anchorage system and/or the design of flexible joints.

A.2 Socket and spigot pipes (see 8.1)

The maximum values of PFA, PMA and PEA are calculated as follows:

$$a) \quad PFA = \frac{20 \cdot e_{min} \cdot R_m}{D \cdot S_F}$$

where

e_{min} is the minimum pipe wall thickness, in millimetres;

D is the mean pipe diameter (DE - e_{min}), in millimetres;

DE is the nominal pipe external diameter (see Tables 16 and 17), in millimetres;

R_m is the minimum tensile strength of ductile iron, in megapascals ($R_m = 420$ MPa; see 4.4.1);

S_F is a safety factor of 3.

The maximum PFA of a pipe is equal to its class number, e.g. PFA 40 for a class 40 pipe.

- b) PMA: as PFA, but with $S_F = 2,5$; therefore:

$$PMA = 1,2 \times PFA .$$

- c) PEA = PMA + 5 bar.

A.3 Fittings for socketed joints (see 8.3)

The maximum values of PFA, PMA and PEA, for fittings with thicknesses as specified in 8.3, are as follows:

- socketed fittings, except tees: their PFA, PMA and PEA are equal to those given in Table A.1;
- socketed tees: their PFA, PMA and PEA may be less than those given in Table A.1; they shall be as given by the manufacturer;
- fittings with one flange, such as double-socket tees with flanged branch, flanged spigots and flanged sockets: their PFA, PMA and PEA are limited by their flange; they are equal to those given in A.4 for the corresponding PN and DN.

For fittings manufactured with thicknesses greater than those specified in 8.3, the PFA, PMA and PEA shall be determined by calculation, testing or by a combination of both and given in the manufacturer's literature.

When other limitations exist due to the joint type or to any specific design arrangement, they shall be as given by the manufacturer.

Table A.1 — Fittings pressure class

DN	Pressure class C	PFA bar	PMA bar	PEA bar
40 to 100	100	100	120	125
125 to 200	64	64	77	82
250 to 350	50	50	60	65
400 to 600	40	40	48	53
700 to 1 400	30	30	36	41
1 500 to 2 000	25	25	30	35

A.4 Flanged pipes (see 8.2) and fittings for flanged joints (see 8.4)

The maximum values for PFA, PMA and PEA are given in Table A.2.

Table A.2 — Flanged pipe and fittings pressures

DN	PN 10			PN 16			PN 25			PN 40		
	PFA	PMA	PEA	PFA	PMA	PEA	PFA	PMA	PEA	PFA	PMA	PEA
40 to 50	See PN 40			See PN 40			See PN 40			40	48	53
60 to 80	See PN 16			16	20	25	See PN 40			40	48	53
100 to 150	See PN 16			16	20	25	25	30	35	40	48	53
200 to 600	10	12	17	16	20	25	25	30	35	40	48	53
700 to 1 200	10	12	17	16	20	25	25	30	35	-	-	-
1 400 to 2 000	10	12	17	16	20	25	25	30	35	-	-	-

A.5 Accessories

The PFA, PMA and PEA of couplings and saddles are those given by the manufacturer. For flange adaptors, they are given in Table A.2.

Annex B (informative)

Longitudinal bending resistance of pipes

Pipes with an aspect ratio (length/diameter) equal to or greater than 25 may be subjected to high stresses due to bending moments caused for example by ground subsidence or by differential settlement.

In order to provide a high degree of safety in such situations, ductile iron pipes withstand the bending moments given in Table B.1, with no visible damage to the pipe wall and to the external and internal coatings. These bending moments have been calculated assuming a pipe of minimum wall thickness for its class and a bending stress in the metal equal to 250 MPa.

Table B.1 — Longitudinal bending moment resistance of pipes

DN	Bending moments (kN·m)			
	Class 40	Class 50	Class 64	Class 100
40	1,6	1,9	2,1	2,4
50	2,3	2,7	3,0	3,5
60	3,2	3,7	4,2	4,8
65	3,7	4,2	4,8	5,5
80	5,3	6,1	6,9	8,0
100	7,8	9,0	10,2	11,8
125	11,7	13,6	15,4	19,0
150	16,4	19,0	21,6	31,2
200	29,2	36,4	46,2	69,4

NOTE 1 These bending moments, expressed in kilonewton metres, correspond to a load of the same value, expressed in kilonewtons, applied at mid-point of a 4 m span.

NOTE 2 Bending moments that can cause failure of the pipes are at least 1,7 times higher than the given values.

Annex C (informative)

Diametral stiffness of pipes

Ductile iron pipes can undergo large ovalizations in operation while keeping all their functional characteristics. Allowable pipe ovalizations, when the pipeline is in service, are given in Table C.1.

NOTE 1 The ovalization is one hundred times the vertical pipe deflection in millimetres divided by the initial pipe external diameter in millimetres.

In order to withstand large heights of cover and/or heavy traffic loads in a wide range of installation conditions, ductile iron pipes have the minimum diametral stiffness values given in Table C.1.

The diametral stiffness S of a pipe is given by the formula:

$$S = 1000 \frac{E \cdot I}{D^3} = 1000 \frac{E}{12} \left(\frac{e_{\text{stiff}}}{D} \right)^3$$

where:

S is the diametral stiffness, in kilonewtons per square metre;

E is the modulus of elasticity of the material, in megapascals (170 000 MPa);

I is the second moment of area of the pipe wall per unit length, in millimetres to the third power;

e_{stiff} is the pipe wall thickness for the calculation of the pipe diametral stiffness, in millimetres;

D is the mean diameter of the pipe ($DE - e_{\text{stiff}}$), in millimetres;

DE is the nominal pipe external diameter, in millimetres.

NOTE 2 The values of S have been calculated with a value of e_{stiff} calculated as follows:

$$e_{\text{stiff}} = e_{\text{min}} + 0,5 (1,3 + 0,001 \cdot \text{DN})$$

The allowable pipe diametral ovalization for the preferred pressure classes is given in Table C.1. These values provide sufficient safety against yield bending of the pipe wall, lining deformation, joint leak tightness and hydraulic capacity of the pipe.

For all pipe pressure classes, pipe internal linings are limited to 3% ovalization for DN 40 to DN 300 and 4% for DN 800 and above. Sizes DN 350 to DN 700 follow a linear interpolation between the 3% and 4% limits. The allowable maximum ovalization for all pipe pressure classes is the lowest value calculated from the bending stress limit (see below) or the lining limits as quoted above. However, manufacturer's catalogues may introduce more stringent limitations.

The pipe allowable ovalization, λ , limited by the yield bending strength of ductile iron, is given by the formula:

$$\lambda = 100 \left[\frac{R_f (DE - e_{\text{nom}})}{SF \times E \times e_{\text{nom}} \times DF} \right]$$

where

R_f is the yield bending strength of the pipe wall material, in megapascals (500 MPa);

DE is the nominal pipe external diameter, in millimetres;

e_{nom} is the nominal wall thickness of the pipe, in millimetres;

SF is the safety factor (= 1,5);

E is the modulus of elasticity of the material, in megapascals (170 000 MPa);

DF is the deformation factor which depends mainly on the pipe diametral stiffness ($DF = 3,5$ for ductile iron).

NOTE 3 For added safety, taking into account that the stress is higher when the thickness is higher, the values for the allowable ovalization (λ), have been determined using a value of e_{nom} calculated as follows:

$$e_{nom} = e_{min} + (1,3 + 0,001 \cdot DN)$$

Table C.1 — Diametral stiffness of pipes of preferred pressure classes

DN	Minimum diametral stiffness kN/m ²			Allowable pipe ovalization %		
	Class 25	Class 30	Class 40	Class 25	Class 30	Class 40
40	-	-	4 800	-	-	0,65
50	-	-	2 900	-	-	0,80
60	-	-	1 790	-	-	0,90
65	-	-	1 470	-	-	1,00
80	-	-	850	-	-	1,20
100	-	-	480	-	-	1,45
125	-	-	260	-	-	1,75
150	-	-	160	-	-	2,05
200	-	-	78	-	-	2,65
250	-	-	74	-	-	2,75
300	-	-	68	-	-	2,90
350	-	46	-	-	3,10	-
400	-	34	-	-	3,20	-
450	-	28	-	-	3,30	-
500	-	27	-	-	3,40	-
600	-	26	-	-	3,60	-
700	17	-	-	3,80	-	-
800	15	-	-	4,00	-	-
900	15	-	-	4,00	-	-
1 000	14,5	-	-	4,00	-	-
1 100	14	-	-	4,00	-	-
1 200	14	-	-	4,00	-	-
1 400	13,5	-	-	4,00	-	-
1 500	13,5	-	-	4,00	-	-
1 600	13,5	-	-	4,00	-	-
1 800	13	-	-	4,00	-	-
2 000	13	-	-	4,00	-	-

Annex D (informative)

Specific coatings, field of use, characteristics of soils

D.1 Alternative coatings

D.1.1 Pipes

The following pipe coatings can also be supplied, depending on the external and internal intended conditions of use:

a) External coatings:

- 1) Zinc rich paint coating having a minimum mass of 220 g/m², with finishing layer;
- 1) Polyethylene sleeve (as a supplement to the zinc coating with finishing layer);
- 2) Alloy of zinc and aluminium with or without other metals, having a minimum mass of 400 g/m², with finishing layer;
- 3) Extruded polyethylene coating in accordance with EN 14628;
- 4) Polyurethane coating in accordance with EN 15189;
- 5) Cement mortar coating in accordance with EN 15542;
- 6) Adhesive tape;

b) Internal coatings (linings):

- 1) Thicker cement mortar lining;
- 2) Cement mortar lining with seal coat;
- 3) Polyurethane lining in accordance with EN 15655;

c) Coating of the joint area:

- 1) Epoxy coating;
- 2) Polyurethane coating.

These external and internal coatings should comply with the appropriate European Technical Specification or, where no European Technical Specification exists, with the appropriate International Standard, national standard or agreed specification.

D.1.2 Fittings and accessories

The following fitting and accessory coatings may also be supplied depending on external and internal intended conditions of use:

a) External coatings:

- 1) Zinc rich paint coating with finishing layer;
 - 2) Polyethylene sleeving (as a supplement to the paint coating or to the zinc rich paint coating with finishing layer);
 - 3) Electro-deposited coating with a mean thickness not less than 70 μm and the local minimum thickness not less than 50 μm , applied on a blast-cleaned and phosphated surface;
 - 4) Polyurethane coating in accordance with EN 15189;
 - 5) Polyamide in accordance with EN 10310;
 - 6) Adhesive tape;
 - 7) Enamel.
- b) internal coatings (linings):
- 1) Thicker cement mortar lining;
 - 2) Cement mortar lining with seal coat;
 - 3) Electro-deposited coating with a mean thickness not less than 70 μm and the local minimum thickness not less than 50 μm , applied on a blast-cleaned and phosphated surface;
 - 4) Polyamide in accordance with EN 10310;
 - 5) Polyurethane lining in accordance with EN 15655;
 - 6) Enamel.

These external and internal coatings should comply with the appropriate European Technical Specification or, where no European Technical Specification exists, with the appropriate International Standard, national standard or agreed specification.

D.2 Field of use in relation to the characteristics of soils

D.2.1 Standard coating

Ductile iron pipes complying with 4.5.2 and ductile iron fittings and accessories complying with 4.6.2 may be buried in contact with a large number of soils, which can be identified by soil studies on site, except:

- soils with a low resistivity, less than 1500 $\Omega\cdot\text{cm}$ when laid above the water table or less than 2500 $\Omega\cdot\text{cm}$ when laid below the water table;
- mixed soils, i.e. comprising two or more soil natures;
- soils with a pH below 6 and a high reserve of acidity;
- soils containing refuse, cinders, slags or polluted by wastes or industrial effluents.

In such soils, and also in the occurrence of stray currents, it is recommended that an additional protection is used (such as polyethylene sleeving) or other types of external coatings as appropriate (see D.1, D.2.2 and D.2.3).

A thicker finishing layer (e.g. 100 μm local minimum of polyurethane or epoxy) may extend the field of use to a resistivity of 1 000 $\Omega\cdot\text{cm}$ when laid above the water table and of 1 500 $\Omega\cdot\text{cm}$ when laid below the water table.

D.2.2 Alloy of zinc and aluminium with or without other metals

Ductile iron pipes coated with an alloy of zinc and aluminium with or without other metals having a minimum mass of 400 g/m² with finishing layer, together with ductile iron fittings coated with an electro-deposited coating having a minimum thickness of 50 µm and applied on a blast-cleaned and phosphated treated surface, or coated with an epoxy coating (see 4.6.1) may be buried in contact with the majority of soils, except:

- acidic peaty soils;
- soils containing refuse, cinders, slag, or polluted by wastes or industrial effluents;
- soils below the marine water table with a resistivity lower than 500 Ω·cm.

In such soils, and also in the occurrence of stray currents, it is recommended to use other types of external coatings adapted to the most corrosive soils (see D.1 and D.2.3).

Evidence of the long term performance of the above mentioned solution (e.g. tests and references) should be provided by the manufacturer.

D.2.3 Reinforced coatings

Ductile iron pipes and fittings with the following external coatings may be buried in soils of all levels of corrosivity:

- Extruded polyethylene coating (pipes), in accordance with EN 14628;
- Polyurethane coating (pipes), in accordance with EN 15189;
- Epoxy coating having a minimum average thickness of 250 µm (fittings) in accordance with EN 14901;
- Fibre reinforced cement mortar coating (pipes), in accordance with EN 15542;
- Adhesive tapes (pipes and fittings).

Annex E (informative)

Field of use, water characteristics

Ductile iron pipelines supplied with internal linings complying with 4.5.3 and 4.6 may be used to convey all types of water intended for human consumption in conformity with the Directive 98/83/EC.

For other types of water, the limits of use are as given in Table E.1, depending on the type of cement used for the lining.

Table E.1 — Field of use for cement mortar linings

Water characteristics	Portland cement	Sulphate resisting cements (including blast-furnace slag cements)	High alumina cement
Minimum value of pH	6	5,5	4
Maximum content (mg/l) of:			
— Aggressive CO ₂	7	15	No limit
— Sulphates (SO ₄ ⁻)	400	3 000	No limit
— Magnesium (Mg ⁺⁺)	100	500	No limit
— Ammonium (NH ₄ ⁺)	30	30	No limit

Annex F (informative)

Calculation method of buried pipelines, heights of cover

F.1 Calculation method

F.1.1 Calculation formula

The method is based on an ovalization calculation according to the formula below:

$$\Delta = \frac{100K (P_e + P_t)}{8S + (f \cdot E')}$$

where

- Δ is the pipe ovalization (%);
- K is the bedding factor;
- P_e is the pressure from earth loading, in kilonewtons per square metre;
- P_t is the pressure from traffic loading, in kilonewtons per square metre;
- S is the pipe diametral stiffness, in kilonewtons per square metre, see Table C.1;
- f is the factor of lateral pressure ($f = 0,061$);
- E' is the modulus of soil reaction, in kilonewtons per square metre.

The ovalization calculated by means of this formula should not exceed the allowable ovalization shown in Table C.1. The allowable ovalization increases with DN while remaining well below the value that the internal cement mortar lining can withstand without damage; in addition, it provides a safety factor of 1,5 with respect to the elastic limit of ductile iron in bending (500 MPa minimum) by limiting the stress in the pipe wall at 330 MPa; finally, it is limited to 4 % for $DN \geq 800$.

F.1.2 Pressure from earth loading

The pressure P_e , uniformly distributed at the top of the pipe over a distance equal to the external diameter, is calculated according to the earth prism method by the formula below:

$$P_e = \gamma H$$

where

- P_e is the pressure from earth loading, in kilonewtons per square metre;
- γ is the unit weight of backfill, in kilonewtons per cubic metre;
- H is the height of cover, in metres, that is the distance from the top of the pipe to the ground surface.

In the absence of other data, the unit weight of the soil is taken as being equal to 20 kN/m³ in order to cover the vast majority of cases. If a preliminary geotechnical survey confirms that the actual unit weight of the backfill will be less than 20 kN/m³, the actual value may be used for determining P_e .

If, however, it appears that the actual value will be more than 20 kN/m³, the actual value should be used.

F.1.3 Pressure from traffic loading

The pressure P_t , uniformly distributed at the top of the pipe over a distance equal to the external diameter, is calculated by means of the formula below:

$$P_t = 40 \cdot \left(1 - 2 \cdot 10^{-4} \cdot DN\right) \frac{\beta}{H}$$

where

P_t is the pressure from traffic loading in kilonewtons per square metre;

β is the traffic load factor.

This formula is not valid for $H < 0,3$ m.

Three types of traffic loading are to be considered:

- traffic areas with main roads, $\beta = 1,5$: this is the general case of all roads, except access roads;
- traffic areas with access roads, $\beta = 0,75$: roads where lorry traffic is prohibited;
- rural areas, $\beta = 0,5$: all other cases.

It should be noted that all pipelines should be designed for at least $\beta = 0,5$ even where they are not expected to be exposed to traffic loading. In addition, pipelines laid in the verge and embankment of roads should be designed to withstand the full traffic loading expected on these roads. Finally, for pipelines which may be exposed to particularly high traffic loading, a factor $\beta = 2$ should be adopted.

F.1.4 Bedding factor, K

The bedding factor K depends upon the soil pressure distribution at the top of the pipe (over a distance equal to the external diameter) and at the invert of the pipe (over a distance corresponding to the theoretical bedding angle 2α).

K normally varies from 0,11 for $2\alpha = 20^\circ$ to 0,09 for $2\alpha = 120^\circ$. The value of 20° corresponds to a pipe which is simply laid on the flat trench bottom, with no compaction effort.

F.1.5 Factor of lateral pressure, f

The factor of lateral pressure f is equal to 0,061; this corresponds to a parabolic distribution of the lateral soil pressure over an angle of 100° , according to the IOWA-Spangler model.

F.1.6 Modulus of soil reaction, E'

The modulus of soil reaction E' depends upon the nature of soil used in the pipe zone and upon the laying conditions.

In a given situation, the modulus of reaction which is required can be determined by means of the formula below:

$$E' = \frac{4000K}{\delta \cdot f} \left(\frac{\beta}{H} (1 - 2 \cdot 10^{-4} DN) + 0,5 H \right) - \frac{8 S}{f}$$

where:

E' is the modulus of soil reaction, in kilonewtons per square metre;

δ is the allowable ovalization, in %.

In Table F.1, values of E' equal to 1000 kN/m², 2000 kN/m² and 5000 kN/m² are taken as guidelines; they correspond to a compaction level which is respectively nil, low and good. The value $E' = 0$ has also been shown as the limit case for unfavourable laying conditions in poor soils (no compaction, water table above the pipe, trench shoring removed after backfilling or embankment conditions).

If a preliminary geotechnical survey allows the determination of the value of the modulus of soil reaction, this value should be taken into account in the calculations.

F.2 Heights of cover

Table F.1 gives the most pessimistic range of values of the allowable heights of cover for each group of diameters. These values can be used without any additional calculation: they are given in metres, with E' in kilonewtons per square metre.

For heights of cover outside the ranges given in Table F.1, and for other laying conditions, a verification can be made using the formulae given in F.1.

Table F.1 — Heights of cover for pipes of preferred pressure classes

DN		40 to 150 Class 40	200 to 300 Class 40	350 to 400 Class 30	450 to 600 Class 30	700 to 2 000 Class 25
K(2 α)		0,110 (20°)	0,110 (20°)	0,105 (45°)	0,105 (45°)	0,103 (60°)
$\beta = 0,50$ Rural areas	$E' = 0$	0,3 to 12,0	0,3 to 7,0	0,3 to 3,8	0,3 to 3,1	0,5 to 1,6
	$E' = 1\ 000$	0,3 to 12,6	0,3 to 7,8	0,3 to 4,8	0,3 to 4,2	0,3 to 3,0
	$E' = 2\ 000$	0,3 to 13,2	0,3 to 8,6	0,3 to 5,7	0,3 to 5,2	0,3 to 4,2
	$E' = 5\ 000$	0,3 to 15,0	0,3 to 11,1	0,3 to 8,5	0,3 to 8,1	0,3 to 7,8
$\beta = 0,75$ Access roads	$E' = 0$	0,3 to 12,0	0,3 to 6,9	0,4 to 3,7	0,5 to 3,0	0,9 to 1,2
	$E' = 1\ 000$	0,3 to 12,6	0,3 to 7,7	0,3 to 4,7	0,4 to 4,1	0,4 to 2,9
	$E' = 2\ 000$	0,3 to 13,2	0,3 to 8,6	0,3 to 5,6	0,3 to 5,1	0,3 to 4,1
	$E' = 5\ 000$	0,3 to 14,9	0,3 to 11,0	0,3 to 8,5	0,3 to 8,1	0,3 to 7,8
$\beta = 1,50$ Main roads	$E' = 0$	0,3 to 11,9	0,4 to 6,7	0,9 to 3,2	1,2 to 2,2	^a
	$E' = 1\ 000$	0,3 to 12,5	0,4 to 7,6	0,7 to 4,3	0,8 to 3,7	1,0 to 2,3
	$E' = 2\ 000$	0,3 to 13,1	0,3 to 8,4	0,6 to 5,4	0,6 to 4,8	0,7 to 3,9
	$E' = 5\ 000$	0,3 to 14,8	0,3 to 10,9	0,4 to 8,3	0,4 to 7,9	0,4 to 7,7
^a Not recommended; only a specific calculation for each case can provide an adequate answer.						

Bibliography

- [1] EN 1514 (all parts), *Flanges and their joints — Dimensions of gaskets for PN-designated flanges*
- [2] EN 10310, *Steel tubes and fittings for onshore and offshore pipelines — Internal and external polyamide powder based coatings*
- [3] EN 14525, *Ductile iron wide tolerance couplings and flange adaptors for use with pipes of different materials: ductile iron, Grey iron, Steel, PVC-U PE, Fibre-cement*
- [4] EN 14628, *Ductile iron pipes, fittings and accessories — External polyethylene coating for pipes — Requirements and test methods*
- [5] EN 15189, *Ductile iron pipes, fittings and accessories — External polyurethane coating for pipes — Requirements and test methods*
- [6] EN 15542, *Ductile iron pipes, fittings and accessories — External cement mortar coating for pipes — Requirements and test methods*
- [7] EN 15655, *Ductile iron pipes, fittings and accessories — Internal polyurethane lining for pipes and fittings — Requirements and test methods*
- [8] EN 45011, *General requirements for bodies operating product certification systems (ISO/IEC Guide 65:1996)*
- [9] EN 45012, *General requirements for bodies operating assessment and certification/registration of quality systems (ISO/IEC Guide 62:1996)*
- [10] EN ISO 6708:1995, *Pipework components — Definition and selection of DN (nominal size) (ISO 6708:1995)*
- [11] ISO 2531, *Ductile iron pipes, fittings, accessories and their joints for water or gas applications*
- [12] Council Directive 98/83/EC [known as “Drinking Water Directive”] of 3 November 1998 on the quality of water intended for human consumption, *Official Journal* L 330, 5.12.1998, p. 32–54
- [13] Council Directive 89/106/EEC [known as “Construction Products Directive”] of 21 December 1988 on the approximation of laws, regulations and administrative provisions of the Member States relating to construction products, *Official Journal* L 40, 11.2.1989, p. 12–26

British Standards Institution (BSI)

BSI is the independent national body responsible for preparing British Standards and other standards-related publications, information and services.

It presents the UK view on standards in Europe and at the international level.

It is incorporated by Royal Charter.

Revisions

British Standards are updated by amendment or revision. Users of British Standards should make sure that they possess the latest amendments or editions.

It is the constant aim of BSI to improve the quality of our products and services. We would be grateful if anyone finding an inaccuracy or ambiguity while using this British Standard would inform the Secretary of the technical committee responsible, the identity of which can be found on the inside front cover.

Tel: +44 (0)20 8996 9001 Fax: +44 (0)20 8996 7001

BSI offers Members an individual updating service called PLUS which ensures that subscribers automatically receive the latest editions of standards.

Tel: +44 (0)20 8996 7669 Fax: +44 (0)20 8996 7001

Email: plus@bsigroup.com

Buying standards

You may buy PDF and hard copy versions of standards directly using a credit card from the BSI Shop on the website www.bsigroup.com/shop. In addition all orders for BSI, international and foreign standards publications can be addressed to BSI Customer Services.

Tel: +44 (0)20 8996 9001 Fax: +44 (0)20 8996 7001

Email: orders@bsigroup.com

In response to orders for international standards, it is BSI policy to supply the BSI implementation of those that have been published as British Standards, unless otherwise requested.

Information on standards

BSI provides a wide range of information on national, European and international standards through its Knowledge Centre.

Tel: +44 (0)20 8996 7004 Fax: +44 (0)20 8996 7005

Email: knowledgecentre@bsigroup.com

Various BSI electronic information services are also available which give details on all its products and services.

Tel: +44 (0)20 8996 7111 Fax: +44 (0)20 8996 7048

Email: info@bsigroup.com

BSI Subscribing Members are kept up to date with standards developments and receive substantial discounts on the purchase price of standards. For details of these and other benefits contact Membership Administration.

Tel: +44 (0)20 8996 7002 Fax: +44 (0)20 8996 7001

Email: membership@bsigroup.com

Information regarding online access to British Standards via British Standards Online can be found at www.bsigroup.com/BSOL

Further information about BSI is available on the BSI website at www.bsigroup.com/standards

Copyright

Copyright subsists in all BSI publications. BSI also holds the copyright, in the UK, of the publications of the international standardization bodies. Except as permitted under the Copyright, Designs and Patents Act 1988 no extract may be reproduced, stored in a retrieval system or transmitted in any form or by any means – electronic, photocopying, recording or otherwise – without prior written permission from BSI. This does not preclude the free use, in the course of implementing the standard of necessary details such as symbols, and size, type or grade designations. If these details are to be used for any other purpose than implementation then the prior written permission of BSI must be obtained. Details and advice can be obtained from the Copyright & Licensing Manager.

Tel: +44 (0)20 8996 7070

Email: copyright@bsigroup.com

BSI Group Headquarters

389 Chiswick High Road London W4 4AL UK

Tel +44 (0)20 8996 9001

Fax +44 (0)20 8996 7001

www.bsigroup.com/standards